

8

Loosen the three bolts holding the rear sub frame and remove it.

9

Loosen the upper attachment of the original shock absorber and swing it backwards.

10

Lift the swing upwards so the lower shock absorber bolt can be removed. Remove the original shock absorber.

11

Fit the Öhlins shock absorber in the same way as the original unit. Fasten it by using the two original bolts.

12

Refit the rear sub frame, the electrical connections, the brake fluid reservoir, the silencer, the right side cover and the seat.

NOTE!

Make sure that all bolts are tightened.

13

Continue your work according to the Owners Manual, section Adjustments.

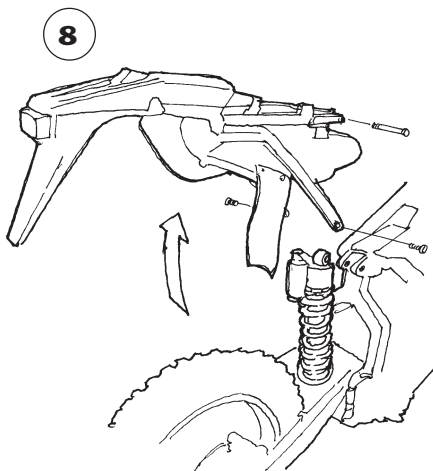

NOTE!

Make sure that all bolts are tightened to the correct torque and that nothing fouls or restricts movement of the shock absorber when the suspension is being fully compressed or extended.

WARNING!

Certain modifications may be necessary when installing the Öhlins shock absorber/suspension. It is essential that the mounting instructions are carefully followed.

Mounting instructions

HO 086 - HONDA XR 650R

Kit content:

Shock absorber, Type 46PRC	HO 086	2
Sticker Öhlins	197-01	1
Sticker Memo note	1180-01	1
C.spanner	710-02	1
Owners Manual		1

Set-up data

Lenght	442 mm
Stroke	105 mm
Rebound adjustment	17 clicks
Compression adjustment	18 clicks
Preload	9 mm

Traction, handling,
comfort and safety



ADVANCED SUSPENSION TECHNOLOGY

Öhlins Racing AB, Box 722, S-194 27 Upplands Väsby, Sweden.

Phone +46 8 590 025 00, fax +46 8 590 025 80.

E-mail: info@ohlins.se

HO086 Issued 000314



ADVANCED SUSPENSION TECHNOLOGY

Safety signals

Important information concerning safety is distinguished in this manual by the following notations.



The Safety alert symbol means: **Caution! Your safety is involved.**

WARNING!

Failure to follow warning instructions could result in **severe or fatal injury** to anyone working with, inspecting or using the suspension, or to bystanders.

CAUTION!

Caution indicates that special precautions must be taken to avoid damage to the suspension.

NOTE!

This indicates information that is of importance with regard to procedures.

Kit contents

Before installing the shock absorber, please check the contents of the kit, listed on the front page of this instruction. If anything is missing, contact your Öhlins dealer.

NOTE!

During storage and transportation, especially at high ambient temperature, the oil and grease used for assembling may run out inside the packing and damage the expanded polystyrene packing material. This is not unusual and is in no way detrimental to the shock absorber.

Before you start

WARNING!

Installing a shock absorber, that is not approved by the vehicle manufacturer, may affect the stability of your vehicle. Öhlins Racing AB cannot be held responsible for any personal injury or damage whatsoever that may occur after fitting the shock absorber. Contact an Öhlins dealer or other qualified person for advice.

Öhlins Racing AB can not be held responsible for any damage whatsoever to shock absorber or vehicle, or injury to persons, if the instructions for fitting and maintenance are not followed exactly. Similarly, the warranty will become null and void if the instructions are not adhered to.

WARNING!

Please study and make certain that you fully understand all the mounting instructions and the owner's manuals before handling this shock absorber kit. If you have any questions regarding proper installation procedures, contact an Öhlins dealer or other qualified person.

WARNING!

The vehicle service manual must be referred to when installing the Öhlins shock absorber.

NOTE!

Öhlins products are subject to continual improvement and development. Consequently, although these instructions include the most up-to-date information available at the time of printing, there may be minor differences between your suspension and this manual. Please consult your Öhlins dealer if you have any questions with regard to the contents of the manual.

Mounting instructions

1

Put the motorcycle on a stand so the rear wheel has ground clearance. Make sure it is steadily positioned and will not fall over.

WARNING!

1. It's advisable to have an Öhlins dealer or other qualified person to fit your shock absorber.
2. Instructions in the vehicle service manual are to be followed when changing the shock absorber.
3. When working on a lifted vehicle it must be securely supported to prevent it from falling.

2

Remove the seat by loosening the rear attachment screws.

2

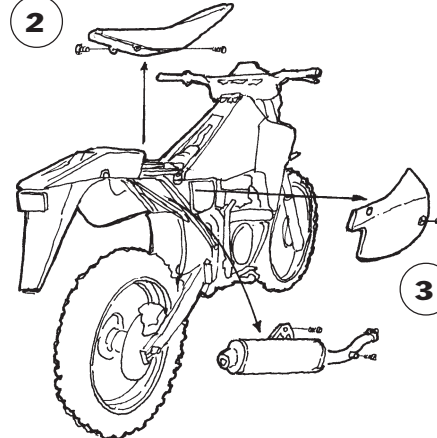

3

Loosen the right side cover.

4

Remove the silencer by loosening the two bracket bolts and the front clamp.

5

Disconnect the rear electrical system wires and remove the ignition coil from its socket.

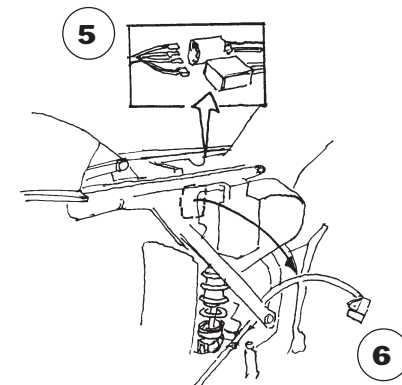

6

Loosen the brake fluid reservoir from its bracket and remove the hose from the frame.

7

Loosen the clamp to the ventilating hose and pull the hose out to the left side.

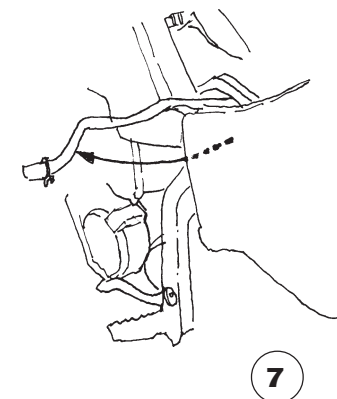

© Öhlins Racing AB.
All rights reserved.

Any reprinting or unauthorized use without the written permission of Öhlins Racing AB is prohibited.
Printed in Sweden.