



Kit Contents			
	Description	Part No	Pcs
1.1	Shock absorber left	BMS 1U00	1
1.2	Shock absorber right	BMS 2U00	1
2	Dust boot	10216-01	2
3	Plastic spring spacer	25602-01	2
4	Spring	47000-23	2
5	Elastic spring spacer	25601-01	2
6	Upper spring seat	25618-35	2
7	Top pin spacer	24629-52	2
8	Washer	24619-03	2
9	Lock nut	24627-05	2
10	Click adjuster	24631-04	2
11	C-spanner	24639-01	1
12	C-spanner	24639-04	1
13	Öhlins sticker kit	10207-01	1
14	Öhlins owner manual		1

👁 Note!

Please note that there can be small differences between your product and the images in these instructions.

👁 Note!

Please note that during storage and transport, especially at high ambient temperature, some of the oil and grease used for assembly may leak and stain the packaging. This will not cause damage to the product, wipe off the excessive oil or grease with a cloth.

👁 Note!

Before you install this product, check the kit contents. If anything is missing, please contact an Öhlins dealer.

⚠ Warning!

Before you install this product, read the Öhlins Owner's manual. This product is an important part of the vehicle and the vehicle stability.

👁 Note!

If your vehicle is equipped with OEM electronic shock absorbers, use Öhlins cancellation kit to avoid error messages.

Shock Absorber Kit for BMW (X-drive and RWD)

1-series (F20, F21)

2-series (F22, F23, G42)

3-series (F30, F31, F34, F35, G20, G21)

4-series (F32, F33, F36, G22, G23, G26)

BMS MU00S1_{front}

Mounting Instructions



ÖHLINS

MOUNTING INSTRUCTIONS

⚠ Warning!

*It is advisable to have an Öhlins dealer install the shock absorber.
When installing, read your Vehicle Service Manual.*

1

Raise the vehicle and put it on jack stands.

⚠ Warning!

Ensure that it is securely supported.

2

Remove the front wheels.

3

Loosen the bolts for the lower strut attachments.

⚠ Caution!

Support the wheel hubs in an appropriate way on each side of the vehicle so that the brake hoses can not be damaged.

4

Loosen the upper attachments. Remove the original struts from the car.

5

Cut the dust boot 30 mm from the lower end with a pair of scissors according to fig 1.

6

Install the dust boot (2), the plastic spacer (3), the spring (4), the elastic spacer (5), the upper spring seat (6), the top pin spacer (7), the OE top mount with bearing, the washer (8) and the M12 lock nut (9) according to fig 2. Tighten the lock nut to 40 Nm.

👁 Note!

When tightening the top mount nut, the shock absorber shaft must be held in position with a 6 mm Allen key.

Fig. 1

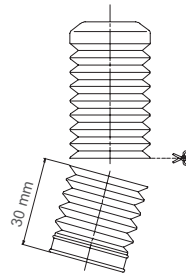
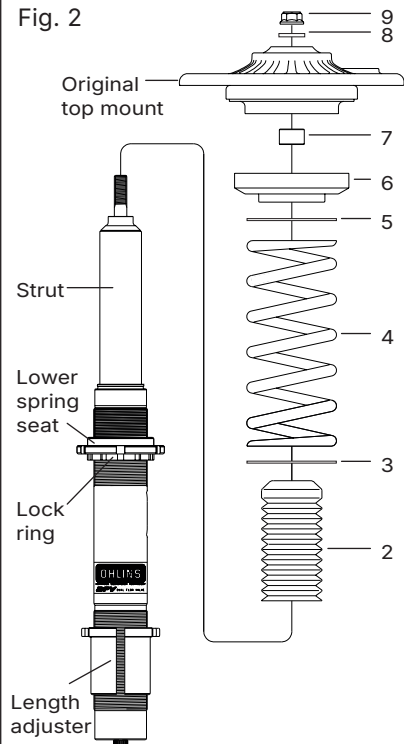

Fig. 2



MOUNTING INSTRUCTIONS

7

Position the length adjuster, lower spring seat and the lock ring according to fig 4 and tighten with the c-spanner.

8

Install the Öhlins McPherson struts with the Öhlins decal facing outwards towards the brake rotor according to fig 3.

9

Fasten the upper attachments.

10

Raise the wheel hub with a jack to remove the freeplay of the lower strut attachment bolts before tightening them.

👁 **Note!**

Make sure that all bolts are tightened to the correct torque and that nothing fouls or restricts movement of the strut when it is being fully compressed or extended. Test this over the whole steering range from lock to lock.

11

Make sure that all removed parts are reinstalled in the same way as they were before the installation of the Öhlins shock absorber.

Fig. 3



ADJUSTMENTS

⚠ Warning!

Before driving, always make sure that the basic settings made by Öhlins are according to recommended Set-up Data. Read about adjustments and setting up in the Öhlins Owner's Manual before you make any adjustments. Contact an Öhlins dealer if you have any questions about setting up the shock absorber.

The preload is 2 mm from a free length of 180 mm, giving 178 mm installed length, see fig 4.

SETUP DATA

Recommended set-up

Setting adjustment		
Track	0-7	clicks
Winding road	5-10	clicks
Street	10-20	clicks
Spring preload	2	mm
Height adjuster (X) F-series	138	mm
Height adjuster (X) G-series RWD	138	mm
Height adjuster (X) G-series X-Drive	118	mm

Recommended spring

47000-23 (80N/mm)

The actual vehicle height

With the spring preload adjuster and length adjuster set to the recommended position, the vehicle is lowered approximately 20-30 mm when compared to the original suspension. Depending on car model and equipment, the spring preload and vehicle height may vary. As the preload or length adjuster is turned one rotation, the position

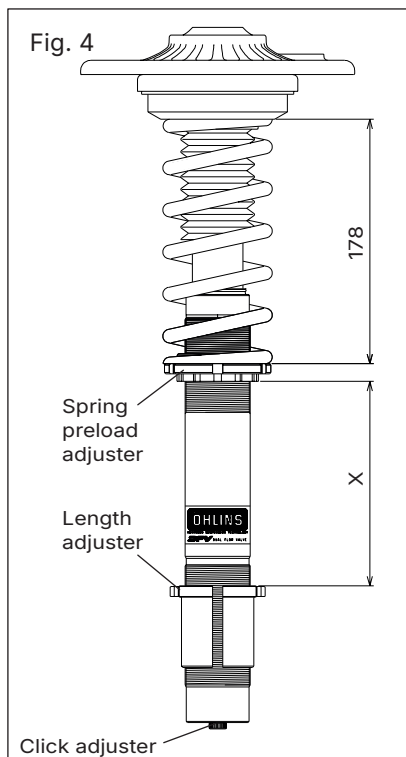

moves 1.5 mm. Adjust the spring preload or length adjuster until you have reached your desired ride height. Make sure that the spring is always preloaded.

⚠ Warning!

The length adjustment range is the standard position $-5/+15$ mm, the spring preload adjustment range is 0-5 mm. Never adjust the spring preload beyond 5 mm preload as that may cause the spring to coil bind.

Öhlins products are subject to continuous improvement and development, therefore, although these instructions include the most up-to-date information available at the time of printing, minor updates may occur.

To find the latest information contact an Öhlins distributor. Please contact Öhlins if you have any questions regarding the contents in this document.

Part no. MI_BMS MU00S1_2_front
Issued 2025-12-17

© Öhlins Group AB. All rights reserved. Any reprinting or unauthorized use without the written permission of Öhlins Group AB is prohibited.

Öhlins Group AB
Box 722
S-194 27 Upplands Väsby, Sweden
Phone +46 8 590 025 00
fax +46 8 590 025 80



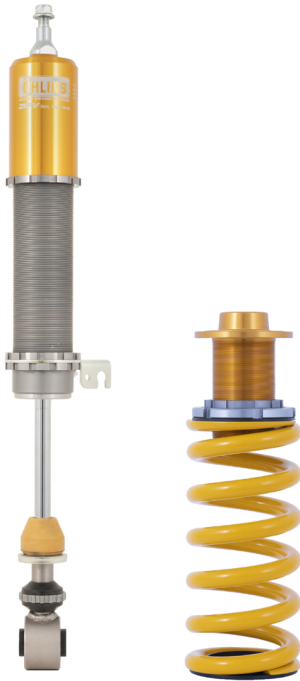

Kit Contents			
	Description	Part No	Pcs
1	Shock absorber rear	BMS 6U00	2
2	End eye spacer	24629-58	4
3	Dust boot	10216-03	2
4	Tie-rap	00231-02	4
5	Lock nut	24626-01	2
6	Spring seat adjuster	24651-10	2
7	Lock nut M52	24636-03	2
8	Spring platform M52	24635-03	2
9	Plastic spring spacer	25602-01	2
10	Spring	47010-47	2
11	Rubber seat	25601-04	2
12	Lower spring seat	25618-04	2

Note!

Please note that there can be small differences between your product and the images in these instructions.

Note!

Please note that during storage and transport, especially at high ambient temperature, some of the oil and grease used for assembly may leak and stain the packaging. This will not cause damage to the product, wipe off the excessive oil or grease with a cloth.

Note!

Before you install this product, check the kit contents. If anything is missing, please contact an Öhlins dealer.

Warning!

Before you install this product, read the Öhlins Owner's manual. This product is an important part of the vehicle and the vehicle stability.

Note!

If your vehicle is equipped with OEM electronic shock absorbers, use Öhlins cancellation kit to avoid error messages.

Shock Absorber Kit for BMW (X-drive and RWD)

1-series (F20, F21)

2-series (F22, F23, G42)

3-series (F30, F31, F34, F35, G20, G21)

4-series (F32, F33, F36, G22, G23, G26)

BMS MU00S1_{rear}



Mounting Instructions

ÖHLINS

MOUNTING INSTRUCTIONS

⚠ Warning!

It is advisable to have an Öhlins dealer install the shock absorber. When installing, read your Vehicle Service Manual.

1

Raise the vehicle and put it on jack stands.

⚠ Warning!

Ensure that it is securely supported.

2

Remove the rear wheels.

3

Remove the lower and the upper attachments and remove the original shock absorbers.

4

Remove the spring together with lower and upper spring seats.

5

Adjust the spring seat (8) position according to fig 4. Tighten the spring seat and lock ring (7) with the c-spanners.

6

On BMW F-series, remove the OEM upper spring cup according to fig. 1.

7

Spring assembly installation:

Mount the lower spring seat (12) in the control arm, the spring (10), the plastic spacer (9) and fit the spring preload adjuster assembly on the spring together with the rubber seat (11) according to fig 2.

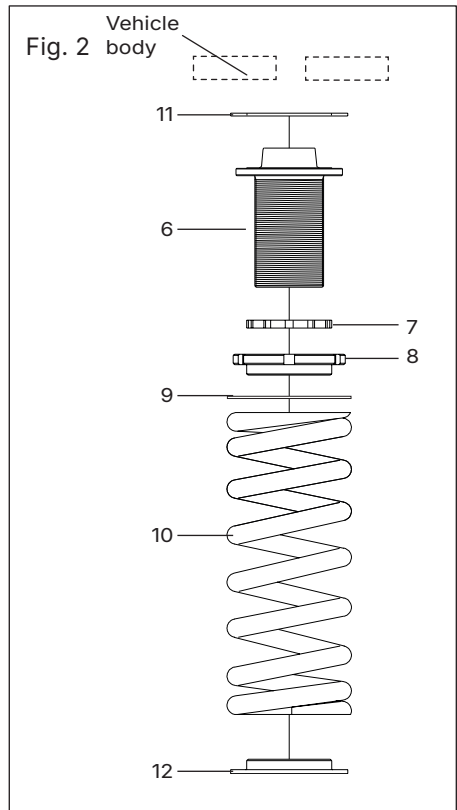
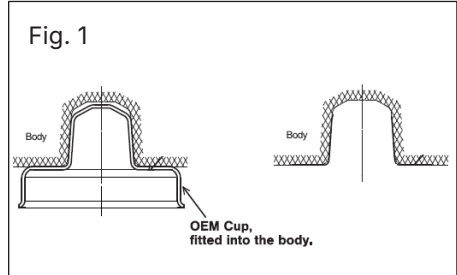

MOUNTING INSTRUCTIONS

👁 Note!

The ABS-bracket on the Öhlins shock absorber is not needed on BMW F-series.

8

Set the shock absorber length with the length adjuster and the ABS-bracket position according to fig 4, tighten the lock ring 50-60 Nm. Mount the dust boot (3) with the tie-raps (4) and the OE top mount with the lock nut (5) according to fig 3. Tighten the lock nut to 30 Nm.

👁 Note!

Make sure that the ABS sensor-wire is not stretched. If so, move the position of the bracket further down.

9

Install the Öhlins shock absorbers on the vehicle.

10

Make sure that all removed parts are reinstalled in the same way as they were before the installation of the Öhlins shock absorber.

👁 Note!

Make sure that all bolts are tightened to the correct torque and that nothing fouls or restricts movement of the shock absorber when it is being fully compressed or extended.

Fig. 3

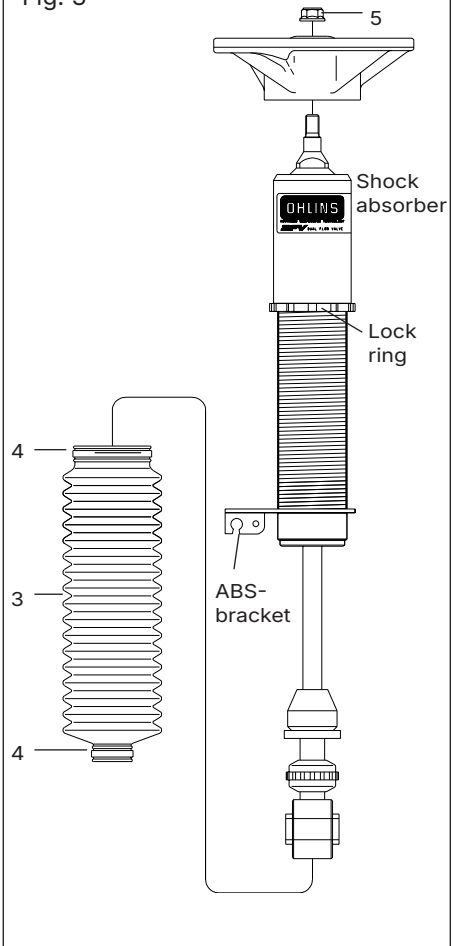

ADJUSTMENTS

⚠ Warning!

Before driving, always make sure that the basic settings made by Öhlins are according to recommended Set-up Data. Read about adjustments and setting up in the Öhlins Owner's Manual before you make any adjustments. Contact an Öhlins dealer if you have any questions about setting up the shock absorber.

SETUP DATA

Recommended set-up

Setting adjustment		
Track	0-7	clicks
Winding road	5-10	clicks
Street	10-20	clicks
Spring preload adjuster height (X)	45-70	mm
Spring preload adjuster height (X) for hybrid vehicle	75-80	mm

Recommended spring

47010-47 (140N/mm)

47010-55 (160N/mm) for hybrid vehicle (spring purchased separately)

Vehicle Height

With the spring preload adjuster set to the Recommended position, the vehicle is lowered approximately 20-30 mm when compared to the original suspension. Depending on car model and equipment, the spring preload and vehicle height may vary. As the height adjuster is turned one rotation, the vehicle height moves approximately 2,5 mm. Adjust the spring preload or height adjuster until you have reached your desired ride height. Make sure that the spring is always preloaded.

Fig. 4

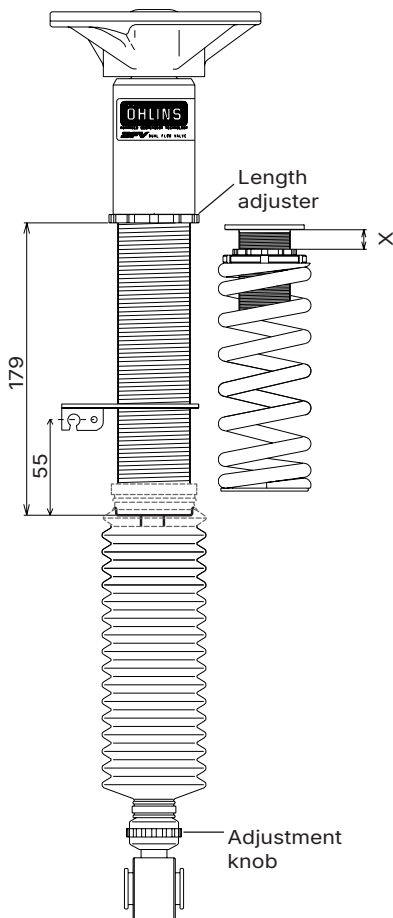

Öhlins products are subject to continuous improvement and development, therefore, although these instructions include the most up-to-date information available at the time of printing, minor updates may occur.

To find the latest information contact an Öhlins distributor. Please contact Öhlins if you have any questions regarding the contents in this document.

Part no. MI_BMS MU00S1_2_rear
Issued 2025-12-17

© Öhlins Group AB. All rights reserved. Any reprinting or unauthorized use without the written permission of Öhlins Group AB is prohibited.

Öhlins Group AB
Box 722
S-194 27 Upplands Väsby, Sweden
Phone +46 8 590 025 00
fax +46 8 590 025 80

