



**👁 Note!**

Please note that this image is a general representation of the product and may differ slightly from your product.

**👁 Note!**

Please note that during storage and transportation, especially at high ambient temperature, some of the oil and grease used for assembling may leak and stain the packaging. This is in no way detrimental to the product, wipe off the excessive oil/grease with a cloth.

**Kit Contents**

	Description	Part No	Pcs
1.1	Shock Absorber left	BMS 1W00	1
1.2	Shock Absorber right	BMS 2W00	1
2	Dust boot	10216-01	2
3	Plastic spring spacer	25602-01	2
4	Spring	47040-21	2
5	Top pin spacer	24629-31	2
6	Washer	24619-03	2
7	Lock nut M12	24627-05	2
8	Anti roll-bar spacer	24629-71	2
9	Nut M6	24626-03	2
10	Screw M6	04757-20	2
11	Length adjuster	24638-10	2
12	C-spanner	24639-04	1
13	C-spanner	24639-01	1
14	Öhlins sticker kit	10207-01	1
15	Öhlins owners manual		1

**👁 Note!**

Before installing this product, check the contents of the kit. If anything is missing, please contact an Öhlins dealer.

**⚠ Warning!**

Before installing this product, read the Öhlins Owner's Manual. The shock absorber is an important part of the vehicle and the vehicle stability.

**👁 Note!**

If the vehicle is equipped with OE electronic shock absorbers, use Öhlins cancellation kit. See products news for part number.

**Shock absorber kit for BMW M2 (G87), M3 RWD (G80) & M4 RWD (G82,G83) - front**

**BMS MWOOS1**

**Mounting Instructions**



**ÖHLINS**

# MOUNTING INSTRUCTIONS

## ⚠ Warning!

We strongly recommend to have an Öhlins dealer install this product.

## ⚠ Warning!

If working on a raised vehicle, ensure that it is securely supported to prevent it from tipping over.

## 👁 Note!

When working on this product, see the Vehicle Service Manual for vehicle specific procedures and important data.

### 1

Raise the vehicle and put it on jack stands.

## ⚠ Warning!

Ensure that it is securely supported.

### 2

Remove the front wheels.

### 3

Loosen the bolts for the lower strut attachments.

## 👉 Caution!

Support the wheel hubs in an appropriate way on each side of the vehicle so that the brake hoses can not be damaged.

### 4

Loosen the sway bar and upper attachments. Remove the original struts from the car.

### 5

Cut the Öhlins dust boot 30 mm from the lower end with a pair of scissors according to figure 2.

### 6

Cut the OEM dust boot just below where the spring fits according to figure 3.

### 7

According to figure 1: Fit the dust boot (2), the plastic spring spacer (3), the spring (4), the spacer (5), the OEM rubber upper spring seat with the original top mount, the washer (6) and the M12 lock nut (7) to the shock absorber. Tighten the lock nut (7) to 35-40 Nm. Mount the OEM accelerometer on the Öhlins bracket with the M6 screw (10) and M6 nut (9). Mount the length adjuster (11) on the shock absorber.

## 👁 Note!

When tightening the top mount nut, the shock absorber top pin must be held in position with a Allen key.

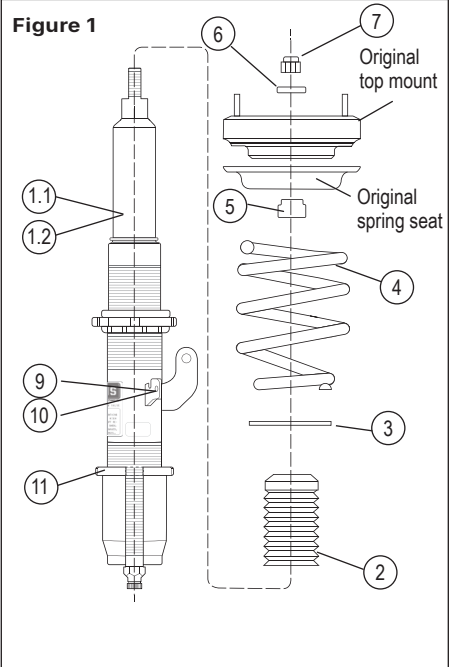

**Figure 2**

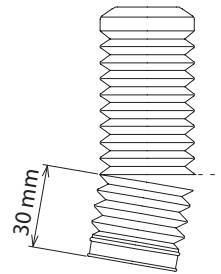

**Figure 3**

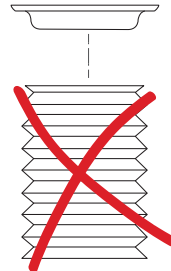

# MOUNTING INSTRUCTIONS

8

Set the spring preload and length adjuster according to figure 6. Tighten the lower spring seat and the lock ring to 50-60Nm.

9

Install the Öhlins McPherson struts on the vehicle in the upper attachments. Insert the strut in the upright and make sure to fit the OEM chord bracket tab in the Öhlins length adjuster or use a pair of pliers to bend the tab outwards according to figure 4.

10

Raise the wheel hub with a jack to remove the freeplay of the lower strut attachment bolts before tightening them.

**👁 Note!**

*Make sure the Öhlins sticker on the strut is facing outwards and that the anti roll bar bracket clears the ABS cable bracket during full wheel turn.*

**👁 Note!**

*Make sure that all bolts are tightened to the correct torque and that nothing fouls or restricts movement of the strut when it is being fully compressed or extended. Test this over the whole steering range from lock to lock*

11

Fit the stabilizer link with the Anti roll-bar spacer (8) according to figure 5.

12

Make sure that all removed parts are reinstalled in the same way as they were before the installation of the Öhlins shock absorber.

**Figure 4**

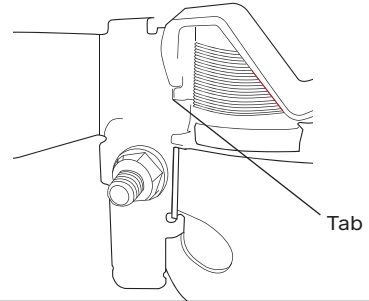

**👁 Note!**

*In some cases there may be a small gap between the upright and the length adjuster. This is considered OK and not an error.*

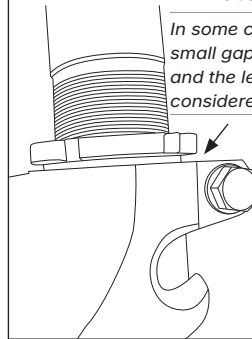

**Figure 5**

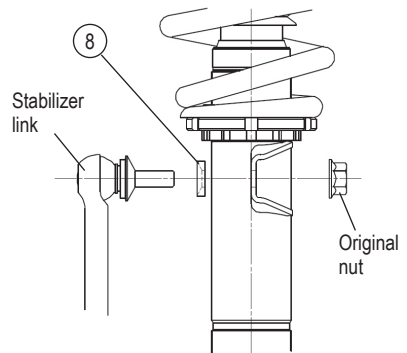

# ADJUSTMENTS

## ⚠ Warning!

Before riding, always make sure that the basic settings made by Öhlins are according to recommended Set-up Data. Read about adjustments and setting up in the Öhlins Owner's Manual before you make any adjustments. Contact an Öhlins dealer if you have any questions about setting up.

The standard preload is 1mm, see figure 6. Make sure to measure the length of the spring only, from to highest point to the lowest point of the spring.

## SETUP DATA

Recommended set-up		
Setting adjustment		
Track	2-7	clicks
Winding road	5-10	clicks
Street	10-20	clicks
Spring preload	1	mm

### Recommended spring

47040-21 (100N/mm)

### The actual vehicle height

With both the preload and length adjustments in their recommended positions, the vehicle is lowered approximately 25 mm when compared to the original suspension. As the length adjuster is turned one rotation, the position moves 1.5 mm.

Figure 6

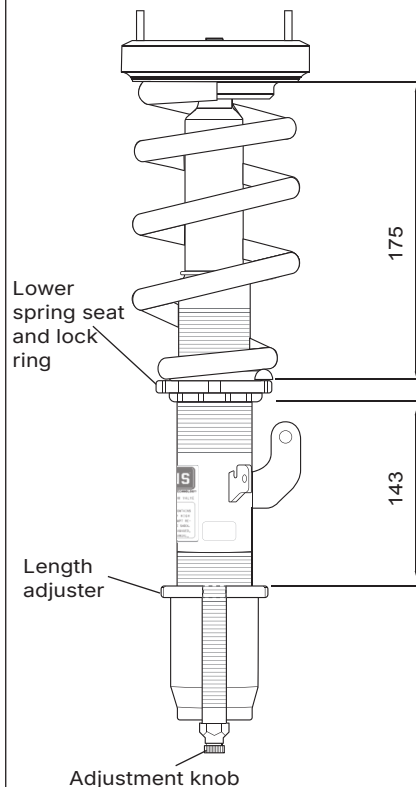

## ⚠ Warning!

The length adjuster range is the standard position  $\pm 15$  mm.

Öhlins products are subject to continuous improvement and development, therefore, although these instructions include the most up-to-date information available at the time of printing, minor updates may occur.

To find the latest information contact an Öhlins distributor. Please contact Öhlins if you have any questions regarding the contents in this document.

Part no. MI\_BMSMW00S1\_front\_1  
Issued 2025-12-17

© Öhlins Group AB. All rights reserved. Any reprinting or unauthorized use without the written permission of Öhlins Group AB is prohibited.

Öhlins Group AB  
Box 722  
S-194 27 Upplands Väsby, Sweden  
Phone +46 8 590 025 00  
fax +46 8 590 025 80





Kit Contents			
	Description	Part No	Pcs
1	Shock Absorber	BMS 6W00	2
2	M14 lock nut	24627-04	2
3	Bushing spacer	24629-32	4
4	Dust boot	10216-03	2
5	Tie-rap	00231-02	2
6	Accelerometer bracket right	24650-13	1
7	Accelerometer bracket left	24650-14	1
8	Screw M5	04757-13	4
9	Stop screw M5	01502-06	2
10	Nut M6	24626-03	2
11	Screw M6	04757-20	2
12	Rubber seat	25601-04	2
13	Spring preload adjuster	24651-14	2
14	Lock ring	24636-03	2
15	Spring seat	24635-03	2
16	Plastic spring spacer	25602-01	2
17	Spring	47010-67	2
18	Lower plastic seat	25618-04	2

**Note!**

Please note that this image is a general representation of the product and may differ slightly from your product.

**Note!**

Please note that during storage and transportation, especially at high ambient temperature, some of the oil and grease used for assembling may leak and stain the packaging. This is in no way detrimental to the product, wipe off the excessive oil/grease with a cloth.

**Note!**

Before installing this product, check the contents of the kit. If anything is missing, please contact an Öhlins dealer.

**Warning!**

Before installing this product, read the Öhlins Owner's Manual. The shock absorber/front fork/steering damper is an important part of the vehicle and the vehicle stability.

## Shock absorber kit for BMW M2 (G87), M3 RWD (G80) & M4 RWD (G82,G83) - rear

# BMS MWOOS1

## Mounting Instructions



**ÖHLINS**

# MOUNTING INSTRUCTIONS

## **⚠ Warning!**

We strongly recommend to have an Öhlins dealer install this product.

## **⚠ Warning!**

If working on a raised vehicle, ensure that it is securely supported to prevent it from tipping over.

## **👁 Note!**

When working on this product, see the Vehicle Service Manual for vehicle specific procedures and important data.

**1**

Raise the vehicle and put it on jack stands.

## **⚠ Warning!**

Ensure that it is securely supported.

**2**

Remove the rear wheels.

**3**

Remove the plastic control arm cover. Remove the lower and the upper attachments and remove the original shock absorbers.

**4**

Remove the springs.

**5**

Set the length of the rear shock absorber according to figure 4 and mount the dust boot (4) with the zip ties (5) on the shock absorber according to figure 2. Lock the dust boot with the stop screw. Mount the accelerometer bracket (6 and 7) with the M5 screw (8) on the dust boot ring, set it in a 45 degree angle from the end eye. Make sure to check the clearance on the vehicle later. Attach the OEM accelerometer on the bracket with the M6 screw (11) and M6 nut (10). Mount the OEM top mount to the shock absorber according to figure 1.

**6**

Assemble the spring adjuster assembly as figure 3 shows and set the adjuster height according to figure 4. Tighten the lock ring (14) and spring seat (15) to 50-60 Nm. Mount the Öhlins spring assembly on the vehicle.

**Figure 1**

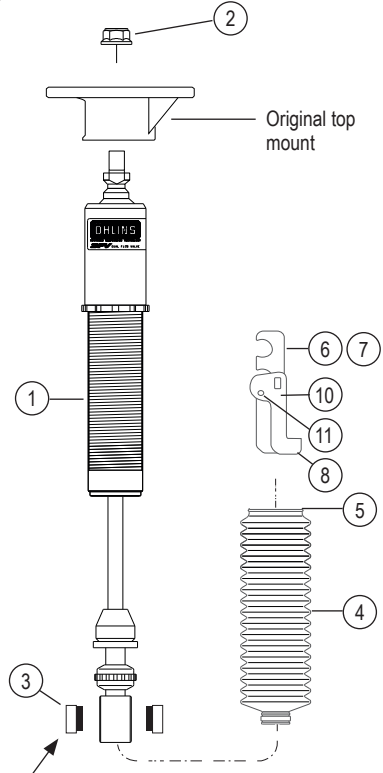

## **👁 Note!**

Bushing spacer. Fit the spacers into the bushing.

# MOUNTING INSTRUCTIONS

7

Install the Öhlins shock absorbers on the vehicle.

8

Make sure that all removed parts are reinstalled in the same way as they were before the installation of the Öhlins shock absorber.

## 👁 **Note!**

*Make sure that all bolts are tightened to the correct torque and that nothing fouls or restricts movement of the shock absorber when it is being fully compressed or extended.*

**Figure 2**

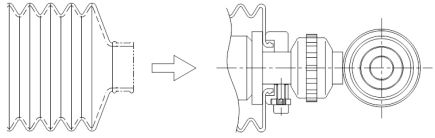

**Figure 3**

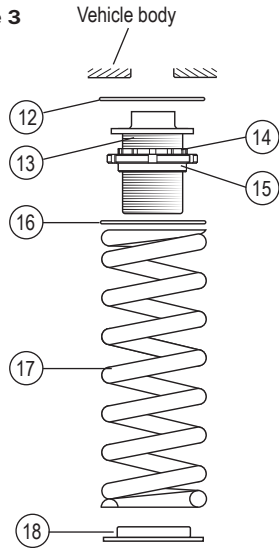

# ADJUSTMENTS

## ⚠ Warning!

Before riding, always make sure that the basic settings made by Öhlins are according to recommended Set-up Data. Read about adjustments and setting up in the Öhlins Owner's Manual before you make any adjustments. Contact an Öhlins dealer if you have any questions about setting up.

## SETUP DATA

Recommended set-up		
Setting adjustment		
Track	2-7	clicks
Winding road	5-10	clicks
Street	10-20	clicks
Spring adjuster height	60	mm
Shock length adjuster G80,G82,G83 (X)	155	mm
Shock length adjuster G87 (X)	165	mm

### Recommended spring

47010-67 (190 N/mm)

### The actual vehicle height

With both the preload and height adjustments in their recommended positions, the vehicle is lowered approximately 20 mm when compared to the original suspension. As the height adjuster is turned one rotation, the position moves 1.5 mm.

Figure 4

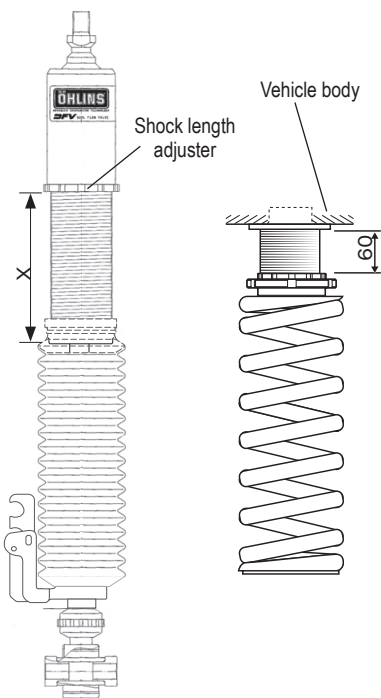

## ⚠ Warning!

The adjustment range is the standard position  $\pm 15$  mm. If the bracket is moved outside the adjustment range, it may come loose.

Öhlins products are subject to continuous improvement and development, therefore, although these instructions include the most up-to-date information available at the time of printing, minor updates may occur.

To find the latest information contact an Öhlins distributor. Please contact Öhlins if you have any questions regarding the contents in this document.

Part no. MI\_BMSMW00S1\_rear\_1  
Issued 2025-12-17

© Öhlins Group AB. All rights reserved. Any reprinting or unauthorized use without the written permission of Öhlins Group AB is prohibited.

Öhlins Group AB  
Box 722  
S-194 27 Upplands Väsby, Sweden  
Phone +46 8 590 025 00  
fax +46 8 590 025 80

