

Kit Contents		
Description	Part No	Pcs
Cartridge kit	FKS 232	1
Preload tube	01460-73	2
Guide ring	21919-01	2
O-ring	00638-96	2
Sticker set Öhlins		1
Owner's manual	07289-01	1

👁 Note!

Please note that there can be small differences between your product and the images in these instructions.

👁 Note!

Please note that during storage and transport, especially at high ambient temperature, some of the oil and grease used for assembly may leak and stain the packaging. This will not cause damage to the product, wipe off the excessive oil or grease with a cloth.

👁 Note!

Before you install this product, check the kit contents. If anything is missing, please contact an Öhlins dealer.

⚠ Warning!

Before you install this product, read the Öhlins Owner's manual. This product is an important part of the vehicle and the vehicle stability.

Cartridge kit for Suzuki SV650

FKS 232

Mounting Instructions



MOUNTING INSTRUCTIONS

⚠ Warning!

We strongly recommend to let an Öhlins dealer install this product.

⚠ Warning!

If you work with a lifted vehicle, make sure that it is safely supported to prevent it from tipping over.

👁 Note!

When you work with this product, see the vehicle service manual for vehicle specific procedures and important data.

👁 Note!

Before you install this product clean the vehicle.

Tool	Part no	Size
Vehicle service manual		
Torque wrench		
Pull-up tool	01765-08	
Stopper plate	02810-03	
Wrench (shaft nut)		13 mm
Hex key (bottom screw)		6 mm
Tool (adjustment housing)		36 mm socket
Tool (adjuster)		14 mm socket
Grease	00146-01	100g
Suspension fluid	01309-xx	

MOUNTING INSTRUCTIONS

Remove the original front fork

👁 **Note!**

The following procedure applies to both front fork legs.

1

Put the motorcycle on a workstand so that the front wheel barely touches the ground.

⚠ **Warning!**

Make sure the vehicle is securely supported so that it will not fall over.

2

Remove front fender, brake calipers, speed sensor (if present) and front wheel.

3

Release main spring preload fully (if present).

4

Note front fork leg position.

5

Loosen upper triple clamp.

6

Loosen (do not remove) top cap 1/2 turn.

7

Loosen lower triple clamp.

8

Remove front fork legs from the triple clamps.

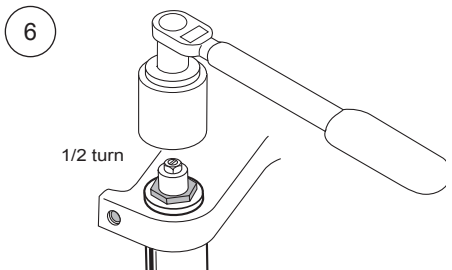
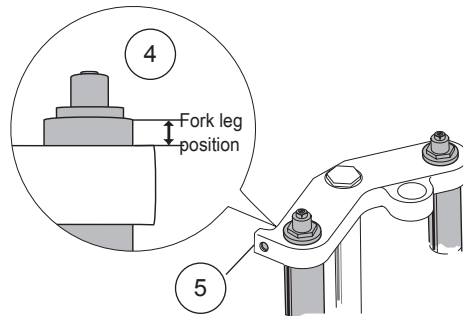
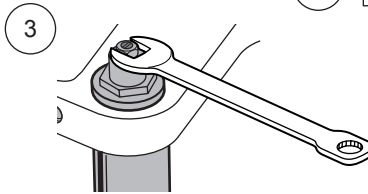
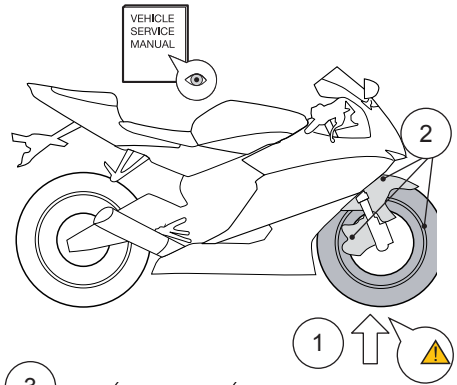

MOUNTING INSTRUCTIONS

Remove the original damping system

⚠ Warning!

Spring compression creates a potential danger because of the violent force that loaded springs are capable of.

Important: When removing the top cap push down the top cap and at the same time pull up the inner tube to prevent uncontrolled release.

1

Use an appropriate tool to loosen and remove top cap from inner tube. Important: When removing the top cap push down the top cap and at the same time pull up the inner tube to prevent uncontrolled release.

2

Remove preload tube, washer and main spring.

👁 Note!

When working with the front fork leg, make sure that the inner tube (A) is in its lowest position to keep the oil lock sleeve (B) correctly positioned inside the inner tube.

3

Drain front fork leg from suspension fluid.

4

Use a 6 mm hex key to remove the bottom screw.

5

Remove damping rod from front fork leg. Do not remove the top out spring.

⚠ Warning!

Make sure the original top out spring is not removed.

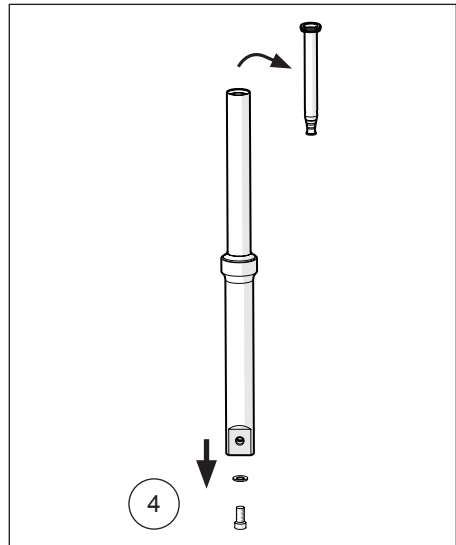
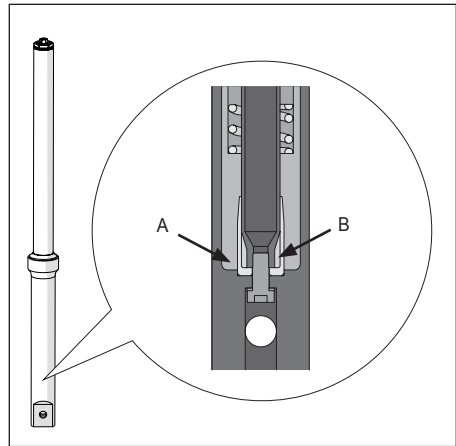
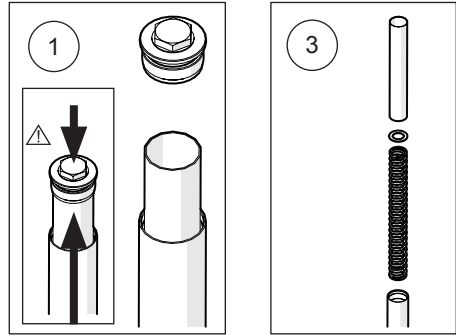

MOUNTING INSTRUCTIONS

Install the Öhlins cartridge kit

⚠ Caution!

Do not mix the parts. Work with only one front fork leg at a time.

⚠ Caution!

The front fork kit consists of one compression cartridge and one rebound cartridge.

Important:

- Install the cartridge marked "Comp" (Compression) in the left side fork leg.
- Install the cartridge marked "Reb" (Rebound) in the right side fork leg.

1

Remove top cap from shaft.

2

Adjust the shaft nut as far up as possible on the shaft, make sure to leave enough threads on the shaft to install the pull up tool.

3

Install pull up tool on shaft. Tighten by hand.

⚠ Caution!

Keep the front fork leg in a vertical position during the installation procedure.

4

Make sure the oil lock sleeve (A) and top out spring (B) are in their correct positions.

⚠ Warning!

Make sure the top out spring is in correct position.

5

Install cartridge in front fork leg.

6

Make sure the cartridge is in its lowest position. Refer to vehicle service manual for threadlocker and tightening torque. Install bottom screw and washer. Use tool 6 mm hex

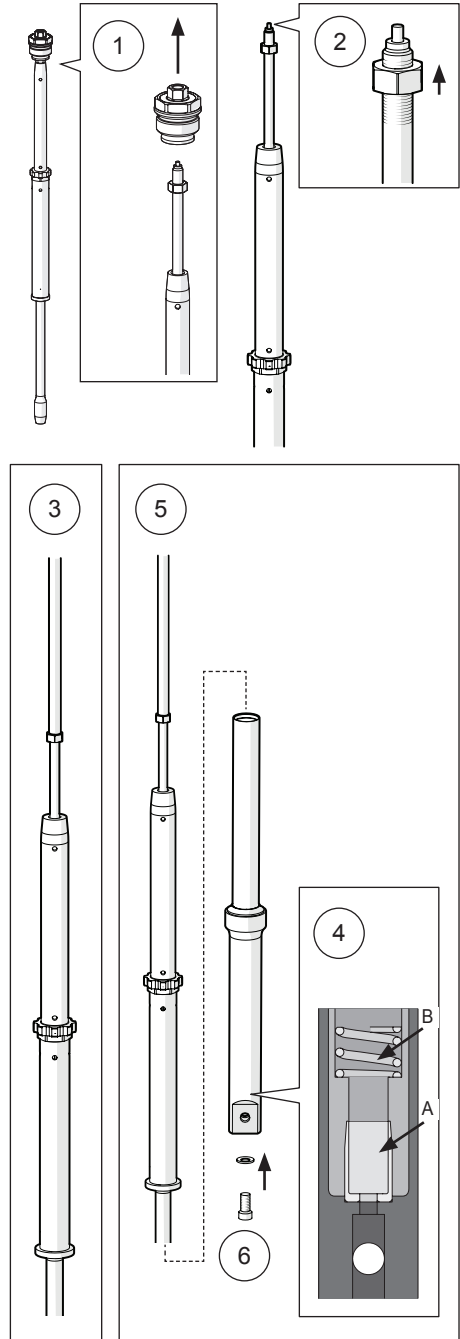

MOUNTING INSTRUCTIONS

key to tighten bottom screw.

7

Pour Ölhlins suspension fluid in front fork leg. If the suspension fluid level comes near the upper end of the inner tube, move the inner tube up and down to release air trapped inside the front fork leg.

8

Pull the inner tube up and down approximately 10 times to release all air trapped inside the front fork leg.

9

Pull the shaft up and down approximately 10 times to release all air trapped inside the cartridge.

10

Make sure the shaft, guide sleeve and inner tube are in their lowest positions. Set the suspension fluid level according to chapter "Setup data".

11

Make sure the mark on the main spring is up. Install main spring (A), guide ring (B) and preload tube (C).

Note!

Make sure the guide ring (B) is positioned correctly.

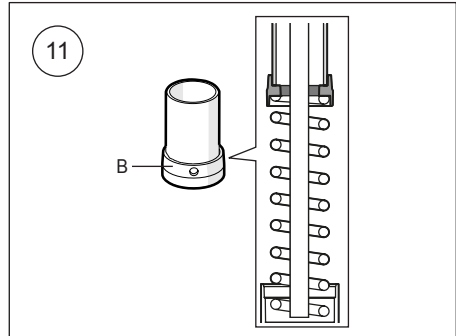
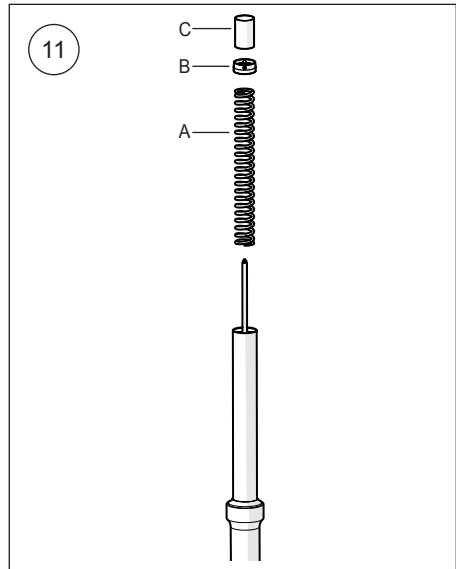
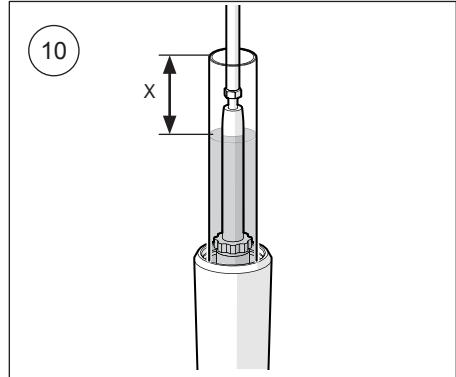

MOUNTING INSTRUCTIONS

12

Push down the preload tube and at the same time pull up the shaft. Carefully insert the stopper plate tool (02810-03) below the shaft nut.

⚠ Warning!

Spring compression creates a potential danger because of the violent force that loaded springs are capable of. Beware of this when you adjust the shaft nut.

13

Remove pull up tool from shaft.

14

Use a 13 mm wrench to adjust the shaft nut until bottomed. Make sure the stopper plate tool stays in place.

15

Install o-ring on top cap. Apply grease on o-ring and top cap thread.

⚠ Warning!

Make sure the compression and rebound adjusters are fully open counter clockwise before installing the top cap.

16

Install top cap on shaft until stop.

👁 Note!

Make sure the top cap is completely bottomed.

17

Use a tool 14 mm socket for the preload adjuster and a 13 mm wrench to tighten the shaft nut to the top cap. Tighten the shaft nut to 12 Nm.

18

Push down the preload tube and carefully remove the stopper plate tool. Make sure the preload tube is correctly installed in the preload socket.

19

Pull up the inner tube and at the same time push down the top cap. Use tool 36 mm socket to tighten the top cap to the inner tube. Tighten the top cap to 10 Nm.

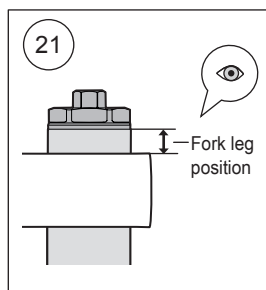
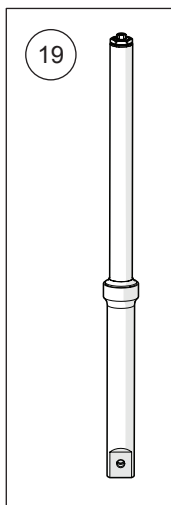
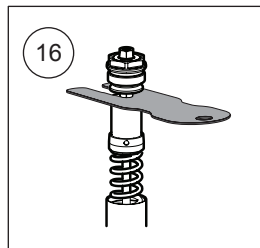
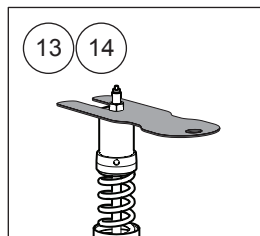
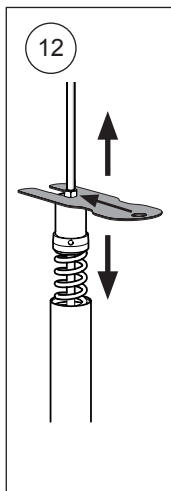

20

Set compression, rebound and preload adjusters according to setup data.

21

Install the front fork in the vehicle at the front fork leg position according to setup data. See the vehicle service manual for instructions.

⚠ Warning!

Make sure to install all removed parts in the same positions as they were before the installation of the Öhlins cartridge kit.

SETUP DATA

Compression adjustment	12	clicks
Rebound adjustment	12	clicks
Öhlins suspension fluid	01309-xx	
Suspension fluid level	150	mm
Fork leg position	Standard	

MAIN SPRING GUIDE

Make sure you choose the correct main spring for your rider weight, driving style and preferences. Below you find a general recommendation of main spring rate for your weight. Contact an authorized Öhlins service center for advice.

Rider weight [kg]	50	60	70	80	90	100	110
Spring rate [N/mm]	8	8.5	8.5	9	9	9.5	9.5
Preload [turns]	3	2	3	2	4	3	4
Part number (pair)	08429-80	08429-85	08429-85	08429-90	08429-90	08429-95	08429-95

👁 **Note!**

Springs are packed in pairs.

Öhlins products are subject to continuous improvement and development, therefore, although these instructions include the most up-to-date information available at the time of printing, minor updates may occur.

To find the latest information contact an Öhlins distributor. Please contact Öhlins if you have any questions regarding the contents in this document.

Part no. MI_FKS232_0
Issued 2023-08-16

© Öhlins Racing AB. All rights reserved. Any reprinting or unauthorized use without the written permission of Öhlins Racing AB is prohibited.

Öhlins Racing AB
Box 722
S-194 27 Upplands Väsby, Sweden
Phone +46 8 590 025 00
fax +46 8 590 025 80



www.ohlins.com