

Note!

Before installing this product, check the contents of the kit. If anything is missing, please check an Öhlins dealer.

Kit Contents

Description	Part No	Pcs
Shock absorber	HO 916	1
Bracket reservoir	03102-15	1
Bracket	60006-25	1
Sleeve 7/12.9-12	61123-18	1
Washer 6.4/12.5/1.6	00426-07	2
Screw M6x45	01046-62	2
Screw M6x12	01046-36	2
Screw M6x14	00382-16	1
C-spanner S46	60710-02	1
Sticker set "ÖHLINS"	10207-01	1
Owners manual	07241-02	1

Note!

Please note that this image is a general representation of the product and may differ slightly from your product.

Note!

Please note that during storage and transportation, especially at high ambient temperature, some of the oil and grease used for assembling may leak and stain the packaging. This is in no way detrimental to the product, wipe off the excessive oil/grease with a cloth.

Warning!

Before installing this product, read the Öhlins Owner's Manual. The shock absorber is an important part of your vehicle and will affect the stability.

Shock Absorber for Honda CB500X

HO 916

Mounting Instructions



MOUNTING INSTRUCTIONS

⚠ Warning!

It is advisable to have an Öhlins dealer install the shock absorber.

⚠ Warning!

If working on a raised vehicle, ensure it is securely supported so that it will not tip over.

👁 Note!

Before mounting this product clean the vehicle thoroughly.

👁 Note!

When working on this product, always see the Vehicle Service Manual for vehicle specific procedures and important data.

- 1 Put the motorcycle on a work stand so that the rear wheel barely touches the ground. Make sure the motorcycle is in a stable position.

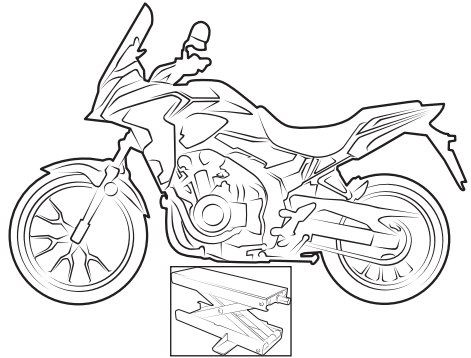

- 2 Remove the seat (A) by using the ignition key (1)

- 3 Remove the plastic fairing (B) by loosening the screw (2)

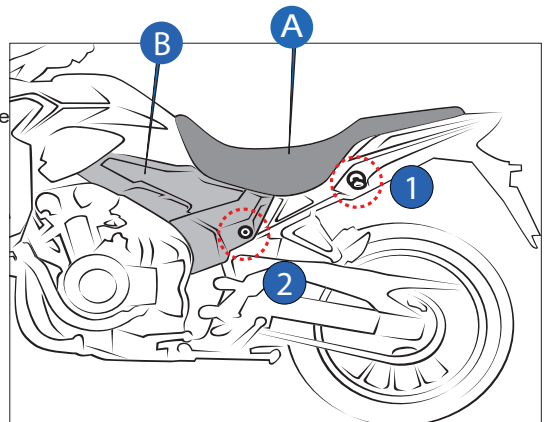

MOUNTING INSTRUCTIONS

4.

Remove the standard shock absorber by loosening the top mounting bolt ① and the lower mounting bolts ② and ③ from the linkage

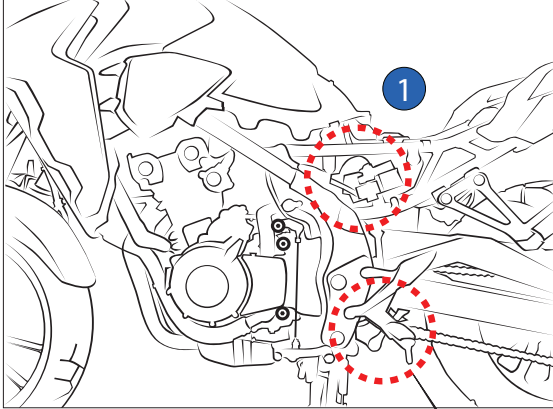

5

To allow the reservoir to pass between the engine and frame

5.1 Remove the shifter bracket C by loosening the screw ④

5.2 Remove the cover D by loosening the screws ⑤⑥

5.3 Reposition the coolant tube by loosening the screw ⑦ (located underneath)

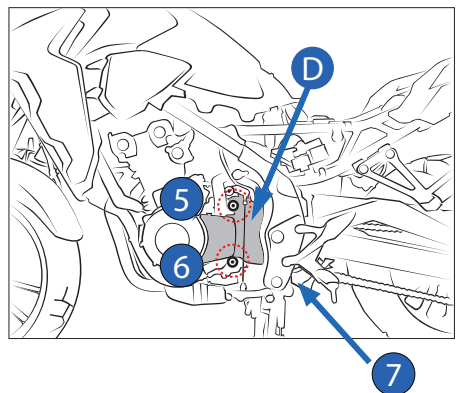
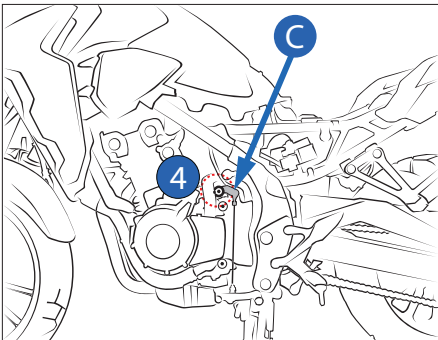
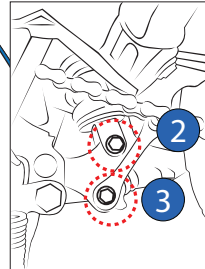

MOUNTING INSTRUCTIONS

6

Rout the reservoir hose to the left side between the engine and the frame as per the diagram below.

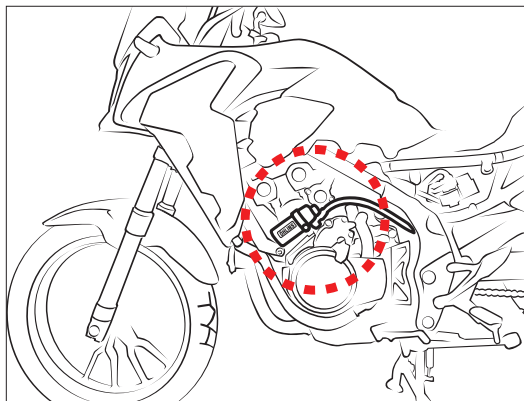

7

Install the Öhlins shock absorber with the hose pointing towards the front of the motorcycle and tighten the upper ① and the lower mounting bolts ② and ③ at a torque value as specified in the vehicle service manual.

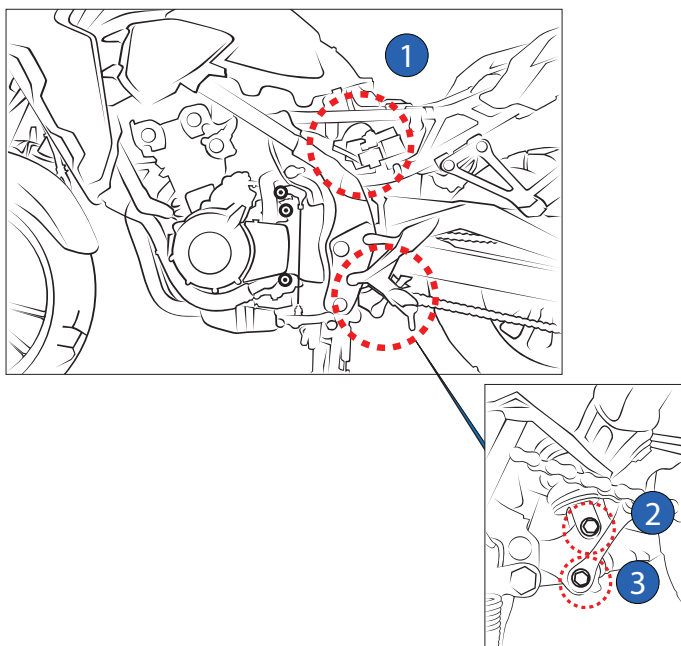

MOUNTING INSTRUCTIONS

8

Install the reservoir into the bracket as per diagram P1 and tighten the screw 01046-62 at a torque value as specified in the vehicle service manual.

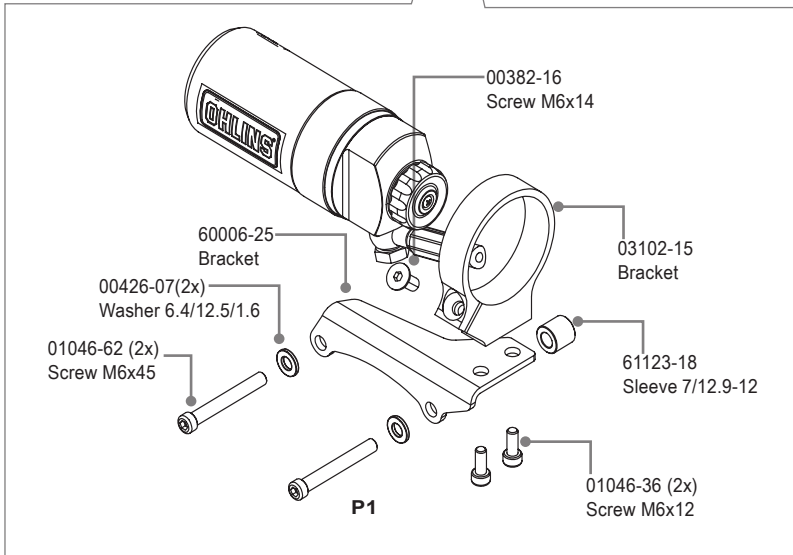
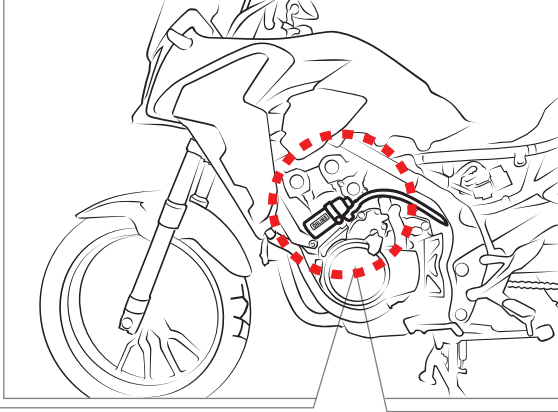

9

Reverse all procedures as necessary

This page intentionally left blank

This page intentionally left blank

ADJUSTMENTS

⚠ Warning!

Before riding, always make sure that the basic settings made by Öhlins are according to recommended Set-up Data. Read about adjustments and setting up in the Öhlins Owner's Manual before you make any adjustments. Contact an Öhlins dealer if you have any questions about setting up.

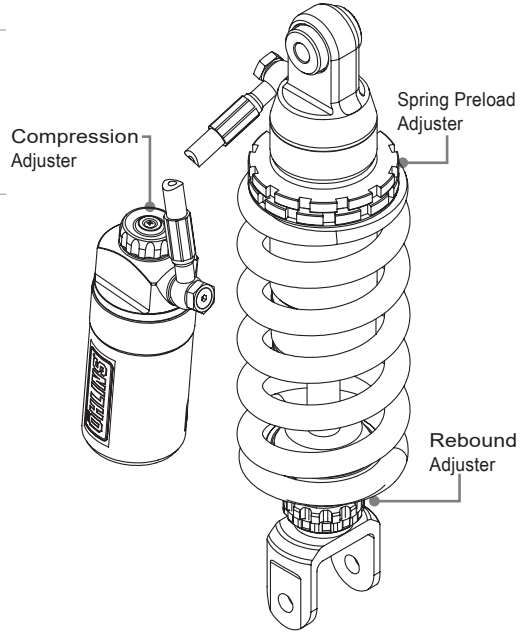

SET-UP DATA

Recommended set-up

Spring Preload.....	9 mm.
Compression adjuster	14 Clicks
Rebound adjuster	16 Clicks

Shock absorber data

Length	318 mm.
Stroke	65 mm.

Spring Installed spring

Part No	60024-49
Free spring length...	170 mm.
Spring rate.....	130 N/mm
Preload adj.range....	[9-13] mm

👁 Öhlins products are subject to continuous improvement and development, therefore, although these instructions include the most up-to-date information available at the time of printing, minor updates may occur.

To find the latest information contact an Öhlins distributor. Please contact Öhlins if you have any questions regarding the contents in this document.

Part no. MI_HO 916_EN_1
Issued 2022-10-10

© Öhlins Asia Co. Ltd. All rights reserved. Any reprinting or unauthorized use without the written permission of Öhlins Racing AB is prohibited.

Öhlins Asia Co. Ltd
700/937 Moo5, Tambol Nongkhaga,
Amphur Phantong, Chonburi Province
20160 Thailand



www.ohlins.com