



### Kit Contents

	Description	Part No	Pcs
1	Shock absorber front	AUS 5U00	2
2	Dust boot	10216-01	2
3	Plastic spacer	25602-01	2
4	Spring	49200-39	2
5	Elastic spacer	25601-01	2
6	Upper spring seat	25618-36	2
7	Top pin spacer 12 mm	24629-54	2
7	Top pin spacer 14 mm	24629-55	2
8	Lock nut M10	24626-01	2
9	Adjustment knob	24631-04	2
10	Upright spacer	24638-08	2
11	C-spanner	24639-01	1
12	C-spanner	24639-04	1
13	Öhlins sticker kit	10207-01	1
14	Öhlins emblem kit	10207-02	1
15	Öhlins owner manual		1

#### 👁 Note!

Please note that there can be small differences between your product and the images in these instructions.

#### 👁 Note!

Please note that during storage and transport, especially at high ambient temperature, some of the oil and grease used for assembly may leak and stain the packaging. This will not cause damage to the product, wipe off the excessive oil or grease with a cloth.

#### 👁 Note!

Before you install this product, check the kit contents. If anything is missing, please contact an Öhlins dealer.

#### ⚠ Warning!

Before you install this product, read the Öhlins Owner's manual. This product is an important part of the vehicle and the vehicle stability.

#### 👁 Note!

If the vehicle is equipped with OE electronic shock absorbers, use Öhlins cancellation kit. See products news for part number.

## Shock Absorber Kit for Audi B9: A4/A5, S4/S5 & RS4/RS5

# AUS MU00S1 front

## Mounting Instructions



# ÖHLINS

# MOUNTING INSTRUCTIONS

## ⚠ Warning!

We strongly recommend to let an Öhlins dealer install this product.

## ⚠ Warning!

If you work with a lifted vehicle, make sure that it is safely supported to prevent it from tipping over.

## 👁 Note!

When you work with this product, see the vehicle service manual for vehicle specific procedures and important data.

## 👁 Note!

Before you install this product clean the vehicle.

1

Raise the vehicle and put it on jack stands.

2

Remove the front wheels.

3

Loosen the bolt for the lower upright attachment.

## 👁 Note!

Support the wheel hubs in an appropriate way on each side of the vehicle so that the brake hoses can not be damaged.

4

Loosen the upper attachments and remove the original struts from the car. Remove the OE rubber positioned inside the top mount, see fig 2.

## 👁 Note!

There are 2 different upright diameters and 2 different top pin sizes depending on vehicle specification. Measure your OE shock top pin diameter and use either the Öhlins 12mm or 14mm top mount spacer (7). Measure your upright diameter and if needed, install the Öhlins upright spacer (10) into the upright before installing the shock absorber.

5

Install the dust boot (2), the plastic spacer (3), the spring (4), the rubber spacer (5), the upper spring seat (6), the top pin spacer (7), the OE top mount and the M10 lock nut (9) according to fig 1. Tighten the lock nut to 25 Nm and install the adjustment knob, tighten to 10 Nm. **Do not install the OE plastic cover on the top mount!**

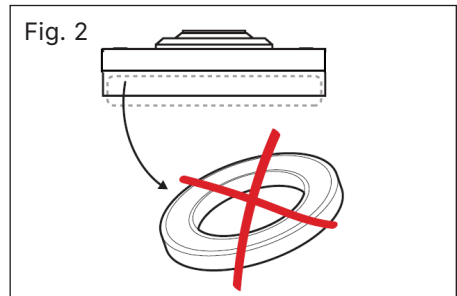
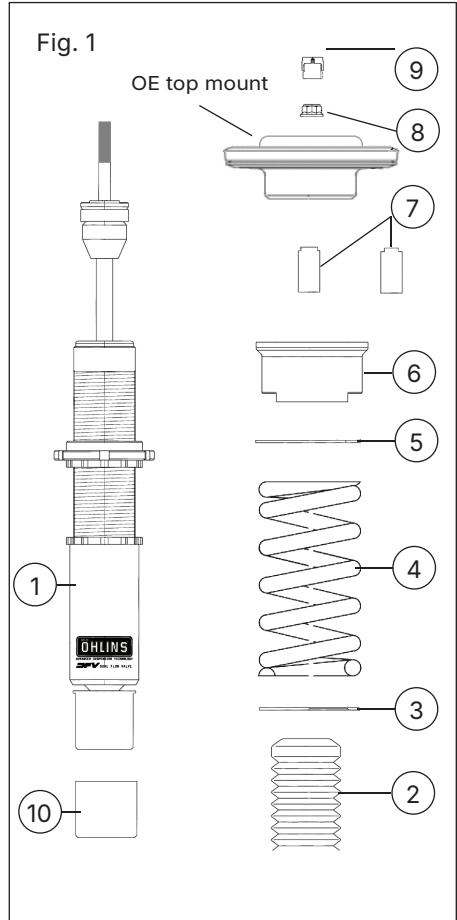

## 👁 Note!

When tightening the top mount nut, the shock absorber shaft must be held in position with an Allen key.

# MOUNTING INSTRUCTIONS

**6**

Position the lower spring seat and the lock ring according to fig 3 and tighten with the c-spanner.

**7**

Fasten the upper attachments to the vehicle body.

**8**

Raise the wheel hub with a jack to remove the freeplay of the lower bracket attachment and tighten the bolt to OE spec.

**👁 Note!**

---

*Make sure that all bolts are tightened to the correct torque and that nothing fouls or restricts movement of the strut when it is being fully compressed or extended. Test this over the whole steering range from lock to lock.*

---

**9**

Make sure that all removed parts are reinstalled in the same way as they were before the installation of the Öhlins shock absorber.

# ADJUSTMENTS

## ⚠ Warning!

Before you drive, always make sure that the setup is according to the recommended setup data. Read about adjustments and setting up in the Öhlins Owner's Manual before you make any adjustments. Contact an Öhlins dealer if you have any questions about setting up.

The recommended preload is 2 mm from a free length of 200 mm, giving 198 mm installed spring length, see fig. 3.

## SETUP DATA

Rebound setting		
Track	2-7	clicks
Winding road	5-10	clicks
Street	10-20	clicks
Spring preload	2-15	mm

### Recommended spring

49200-39 (120N/mm)

### The actual vehicle height

With the preload and height adjuster in their recommended position, the vehicle is lowered approximately 35 mm when compared to the original suspension. Depending on car model and equipment, the spring preload may vary. Adjust the spring preload or height adjuster until you have reached your desired ride height. Make sure that the spring is always preloaded.

Fig. 3

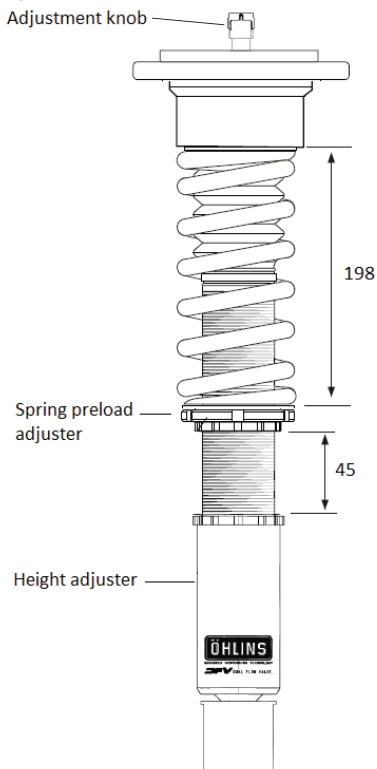

Öhlins products are subject to continuous improvement and development, therefore, although these instructions include the most up-to-date information available at the time of printing, minor updates may occur.

To find the latest information contact an Öhlins distributor. Please contact Öhlins if you have any questions regarding the contents in this document.

Part no. MI\_AUS MU00S1\_0  
Issued 2025-12-11

© Öhlins Group AB. All rights reserved. Any reprinting or unauthorized use without the written permission of Öhlins Group AB is prohibited.

Öhlins Group AB  
Box 722  
S-194 27 Upplands Väsby, Sweden  
Phone +46 8 590 025 00  
fax +46 8 590 025 80





Kit Contents			
Pos nr	Description	Part No	Pcs
1	Shock absorber rear	AUS 6U00	2
2	End eye spacer	24629-56	4
3	Dust boot	10216-03	2
4	Tie-rap	00231-02	4
5	Top pin spacer	24629-57	2
6	Lock nut M10	24618-02	2
7	Spring preload adjuster	24651-11	2
8	Lock nut M52	24636-03	2
9	Spring platform M52	24635-03	2
10	Plastic spacer	25602-01	2
11	Spring	49180-47	2
12	Lower spring seat	25618-33	2

**Note!**

Please note that there can be small differences between your product and the images in these instructions.

**Note!**

Please note that during storage and transport, especially at high ambient temperature, some of the oil and grease used for assembly may leak and stain the packaging. This will not cause damage to the product, wipe off the excessive oil or grease with a cloth.

**Note!**

If the vehicle is equipped with OE electronic shock absorbers, use Öhlins cancellation kit. See product news for part number.

**Note!**

Before you install this product, check the kit contents. If anything is missing, please contact an Öhlins dealer.

**Warning!**

Before you install this product, read the Öhlins Owner's manual. This product is an important part of the vehicle and the vehicle stability.

## Shock Absorber Kit for Audi B9: A4/A5, S4/S5 & RS4/RS5

# AUS MU00S1 rear

## Mounting Instructions



**ÖHLINS**

# MOUNTING INSTRUCTIONS

## **⚠ Warning!**

We strongly recommend to let an Öhlins dealer install this product.

## **⚠ Warning!**

If you work with a lifted vehicle, make sure that it is safely supported to prevent it from tipping over.

## **👁 Note!**

When you work with this product, see the vehicle service manual for vehicle specific procedures and important data.

## **👁 Note!**

Before you install this product clean the vehicle.

**1**

Raise the vehicle and put it on jack stands.

**2**

Remove the rear wheels.

**3**

Remove the lower and the upper attachments and remove the original shock absorbers.

**4**

Remove the spring.

**5**

Adjust the spring seat on the spring preload adjuster according to fig 3. Tighten the lock ring with the c-spanners.

**6**

Install the lower plastic spring seat (12) in the control arm. It may be needed to add some force do get the plastic spring seat fitted into the hole.

Install the Öhlins spring and the spring preload adjuster on the vehicle according to fig 2.

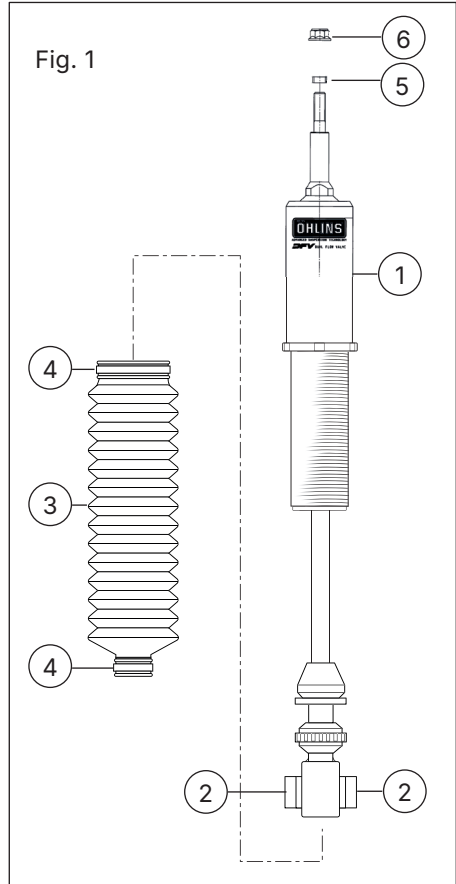

# MOUNTING INSTRUCTIONS

7

Mount the parts on the Öhlins shock absorber according to fig 1 and install the OE top mount. Tighten the top nut to 35Nm.

👁 **Note!**

*There are 2 different top pin sizes depending on vehicle specification. Measure your OE shock top pin diameter and if needed, add the Öhlins top pin spacer (6).*

8

Install the Öhlins shock absorbers on the vehicle and tighten the top mount bolts and lower bolt to OE spec.

👁 **Note!**

*Make sure that all bolts are tightened to the correct torque and that nothing fouls or restricts movement of the shock absorber when it is being fully compressed or extended.*

9

Make sure that all removed parts are reinstalled in the same way as they were before the installation of the Öhlins shock absorber.

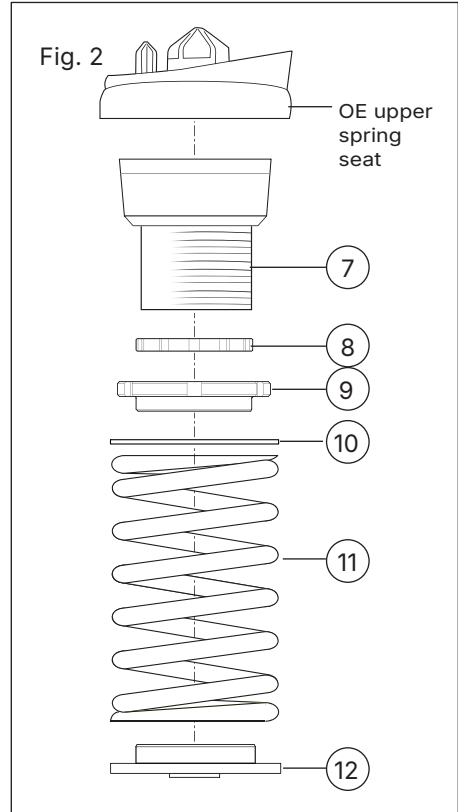

# ADJUSTMENTS

## ⚠ Warning!

Before you ride/drive, always make sure that the setup is according to the recommended setup data. Read about adjustments and setting up in the Öhlins Owner's Manual before you make any adjustments. Contact an Öhlins dealer if you have any questions about setting up.

## SETUP DATA

Rebound setting		
Track	2-7	clicks
road	Winding	5-10
	Street	10-20
Spring preload adjuster height (X)	10-20	mm

### Recommended spring

49180-47 (140N/mm)

### The actual vehicle height

With the preload in their recommended position (15mm), the vehicle is lowered approximately 35 mm when compared to the original suspension. Depending on car model and equipment, the spring preload may vary. Adjust the spring preload until you have reached your desired height. Make sure that the spring is always preloaded.

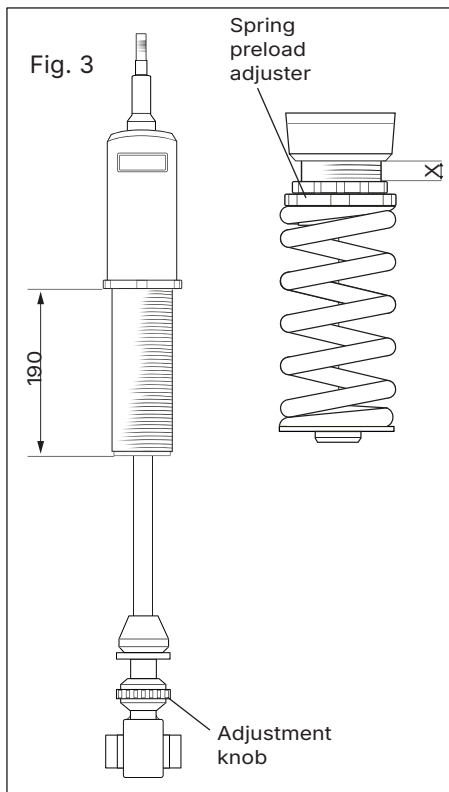

Öhlins products are subject to continuous improvement and development, therefore, although these instructions include the most up-to-date information available at the time of printing, minor updates may occur.

To find the latest information contact an Öhlins distributor. Please contact Öhlins if you have any questions regarding the contents in this document.

Part no. MI\_AUS MU00S1\_0  
Issued 2025-12-11

© Öhlins Group AB. All rights reserved. Any reprinting or unauthorized use without the written permission of Öhlins Group AB is prohibited.

Öhlins Group AB  
Box 722  
S-194 27 Upplands Väsby, Sweden  
Phone +46 8 590 025 00  
fax +46 8 590 025 80

