

Note!

Please note that this image is a general representation of the product and may differ slightly from your product.

Note!

Please note that during storage and transportation, especially at high ambient temperature, some of the oil and grease used for assembling may leak and stain the packaging. This is in no way detrimental to the product, wipe off the excessive oil/grease with a cloth.

Note!

Before installing this product, check the contents of the kit. If anything is missing, please check an Öhlins dealer.

Kit Contents

Description	Part No	Pcs
Shock absorber	LA 342	2
Screw M10X55	64628-05	2
Nut M10	00430-01	2
Washer 10.5/20/2	60426-01	2
Washer 10/28/0.2	63118-15	4
Tool preload adjuster (" L")	03199-03	1
Sticker set "ÖHLINS"	10207-01	1
Owners manual road & track	07241-02	1

Warning!

Before installing this product, read the Öhlins Owner's Manual. The shock absorber is an important part of your vehicle and will affect the stability.

Shock Absorber for Lambretta G350 - Front

LA 342

Mounting Instructions

MOUNTING INSTRUCTIONS

⚠ Warning!

It is advisable to have an Öhlins dealer install the shock absorber.

👁 Note!

Before mounting this product clean the vehicle thoroughly.

⚠ Warning!

If working on a raised vehicle, ensure it is securely supported so that it will not tip over.

👁 Note!

When working on this product, always see the Vehicle Service Manual for vehicle specific procedures and important data.

1

Put the motorcycle on center stand/work stand so that the rear wheel barely touches the ground. Make sure the motorcycle is in a stable position.

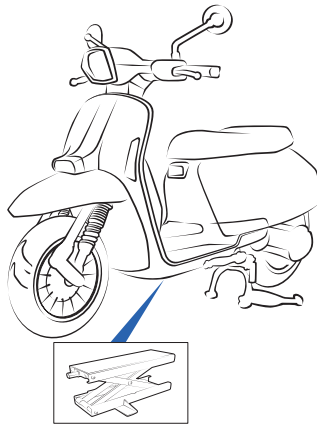

2

Remove the standard shock absorber **A** by loosening the screw **1** from the lower mounting and the screw and washer **2** from the upper mounting.

Repeat the operation on the opposite side.

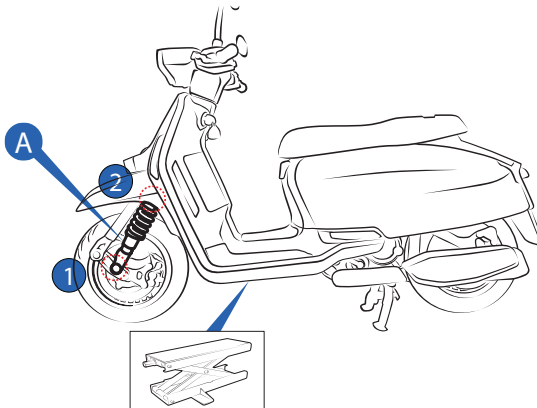

MOUNTING INSTRUCTIONS

3.

Install the Öhlins shock absorber by following diagram shown below (Diagram A).
Tighten at the torque value as specified in the vehicle service manual.

Reverse all the procedures as necessary.

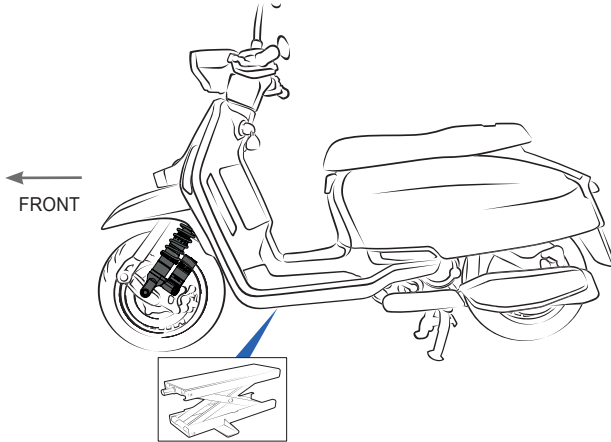
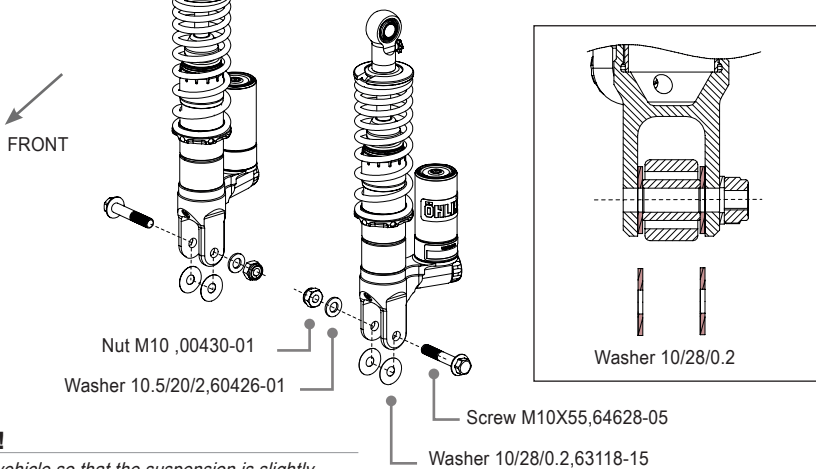

Diagram A.

Right side mounting

Left side mounting



Note!

Lower the vehicle so that the suspension is slightly compressed before tightening the screws.

Caution!

Ensure that all screws are tightened to the correct torque and that nothing fouls or restricts movement of the shock absorber when the suspension is fully compressed or extended.

ADJUSTMENTS

Warning!

Before riding, always make sure that the basic settings made by Öhlins are according to recommended Set-up Data. Read about adjustments and setting up in the Öhlins Owner's Manual before you make any adjustments. Contact an Öhlins dealer if you have any questions about setting up.

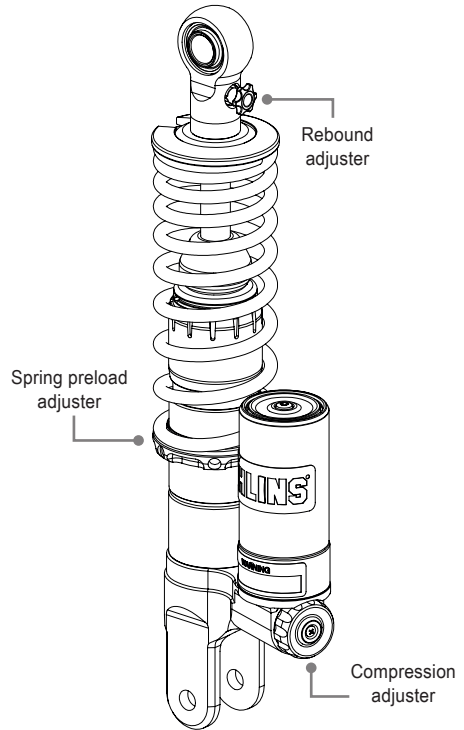

SET-UP DATA

Recommended set-up

Spring Preload 3 mm
Compression adjuster 20 Clicks
Rebound adjuster 14 Clicks

Spring data Installed spring

Part No 66395-01
Free spring length ... 150 mm
Spring rate Prog. 16-28 N/mm
Preload adj.range ... [0-9] mm

Shock absorber data

Length 327 mm
Stroke 72.5 mm

 Öhlins products are subject to continuous improvement and development, therefore, although these instructions include the most up-to-date information available at the time of printing, minor updates may occur.

To find the latest information contact an Öhlins distributor. Please contact Öhlins if you have any questions regarding the contents in this document.

Part no. MI_LA 342_EN_0
Issued 2024-05-15

© Öhlins Asia Co. Ltd. All rights reserved. Any reprinting or unauthorized use without the written permission of Öhlins Racing AB is prohibited.

Öhlins Asia Co. Ltd
700/937 Moo5, Tambol Nongkhaga,
Amphur Phantong, Chonburi Province
20160 Thailand



www.ohlins.com