

👁 **Note!**

Before installing this product, check the contents of the kit. If anything is missing, please contact an Öhlins dealer.

Kit Contents

Description	Part No	Pcs
Shock absorber	HO 129	1
Bracket reservoir 44	03102-15	1
Bracket, Reservoir	60006-32	1
Screw M6x14	00382-16	1
Screw M6x12	05404-01	2
Tie-rap	60231-01	1
C-spanner S46	60710-02	1
Sticker R&T "ÖHLINS"	10207-01	1
Owners manual MX-Enduro	07251-02	1

👁 **Note!**

Please note that this image is a general representation of the product and may differ slightly from your product.

👁 **Note!**

Please note that during storage and transportation, especially at high ambient temperature, some of the oil and grease used for assembling may leak and stain the packaging. This is in no way detrimental to the product, wipe off the excessive oil/grease with a cloth.

⚠ **Warning!**

Before installing this product, read the Öhlins Owner's Manual. The shock absorber is an important part of your vehicle and will affect the stability.

Shock Absorber for Honda CRF300L

HO 129

Mounting Instructions



MOUNTING INSTRUCTIONS

⚠ Warning!

It is advisable to have an Öhlins dealer install the shock absorber.

⚠ Warning!

If working on a raised vehicle, ensure it is securely supported so that it will not tip over.

👁 Note!

Before mounting this product clean the vehicle thoroughly.

👁 Note!

When working on this product, always see the Vehicle Service Manual for vehicle specific procedures and important data.

1

Put the motorcycle on a work stand so that the rear wheel barely touches the ground.

Make sure the motorcycle is in a stable position.

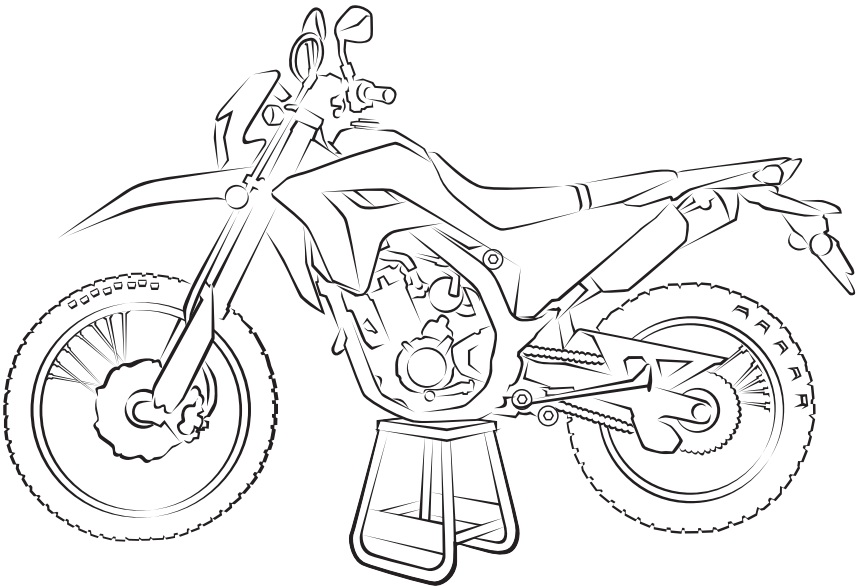

MOUNTING INSTRUCTIONS

2.

Remove the standard shock absorber by loosening the upper mounting bolt (1) and the lower mounting bolts (2) (3) from the linkage.

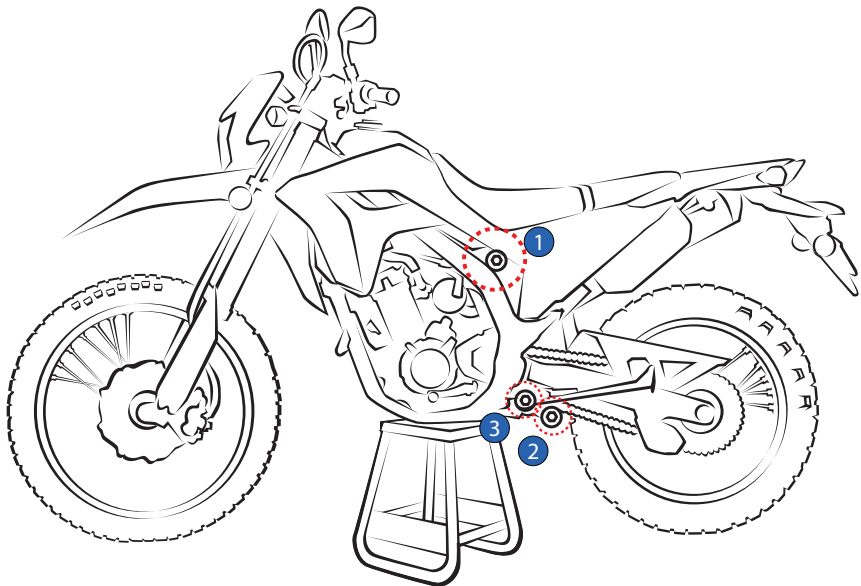

MOUNTING INSTRUCTIONS

3.

In order to rout the reservoir to the left side of the motorcycle.

Proceed as per following instructions:

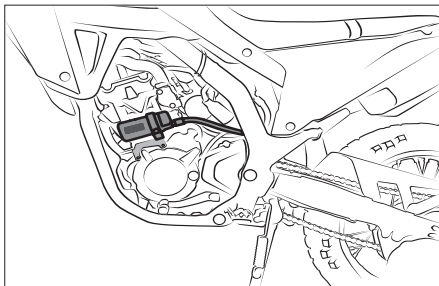

On the right side

3.1

Remove the plastic cover (A) by loosening the screw ①.

Loosen the nut ② located underneath the cover (A)

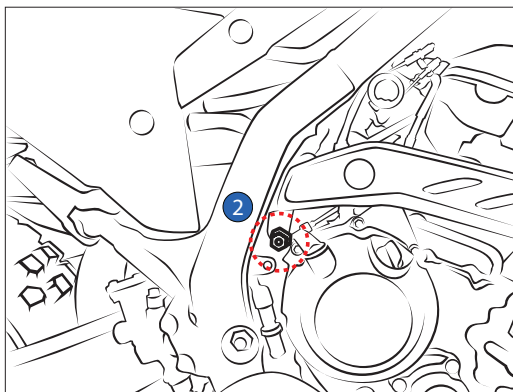
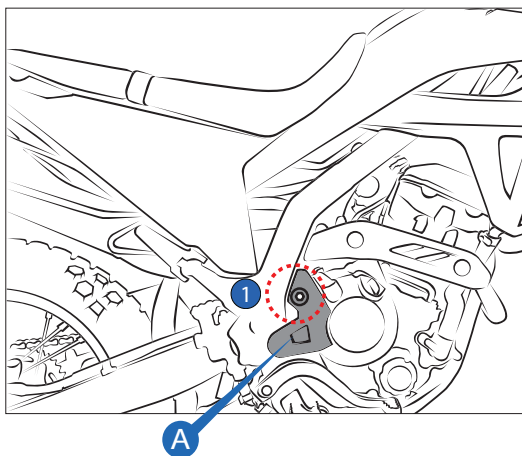

MOUNTING INSTRUCTIONS

On the left side

3.2

Remove the sprocket cover (B) by loosening the screws ① ②

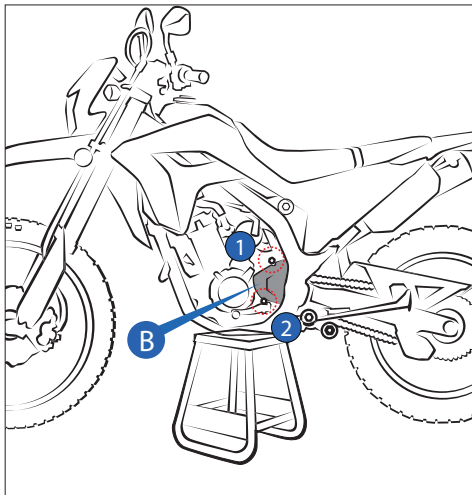

3.3

Remove the evap canister bracket (C) by loosening the screws ① ② ③ ④

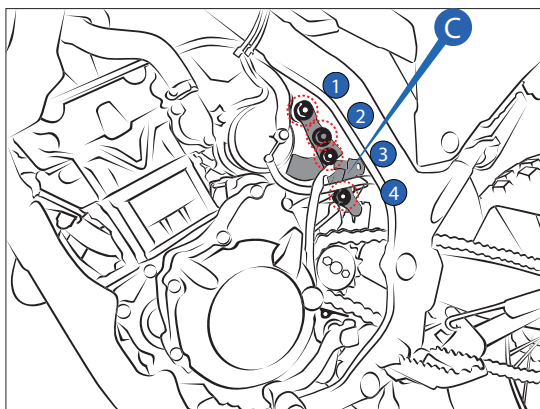

MOUNTING INSTRUCTIONS

4.

Install the Öhlins shock absorber with the hose pointing to the left side of the motorcycle.

Tighten the upper ① and the lower mounting bolts ② and ③ at a torque value as specified in the vehicle service manual.

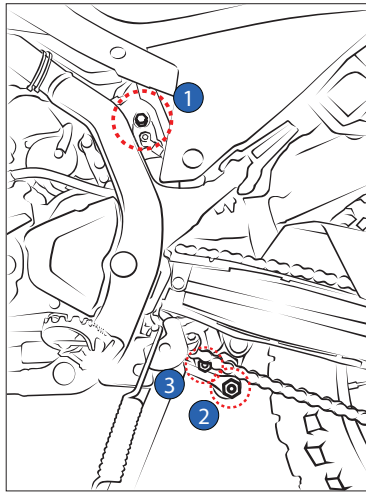

Note!

Lower the vehicle so that the suspension is slightly compressed before tightening the screws.

Caution!

Ensure that all screws are tightened to the correct torque and that nothing fouls or restricts movement of the shock absorber when the suspension is fully compressed or extended.

MOUNTING INSTRUCTIONS

5. Rout the reservoir to the left side of the motorcycle as per diagram P1
6. Reverse all procedures as necessary

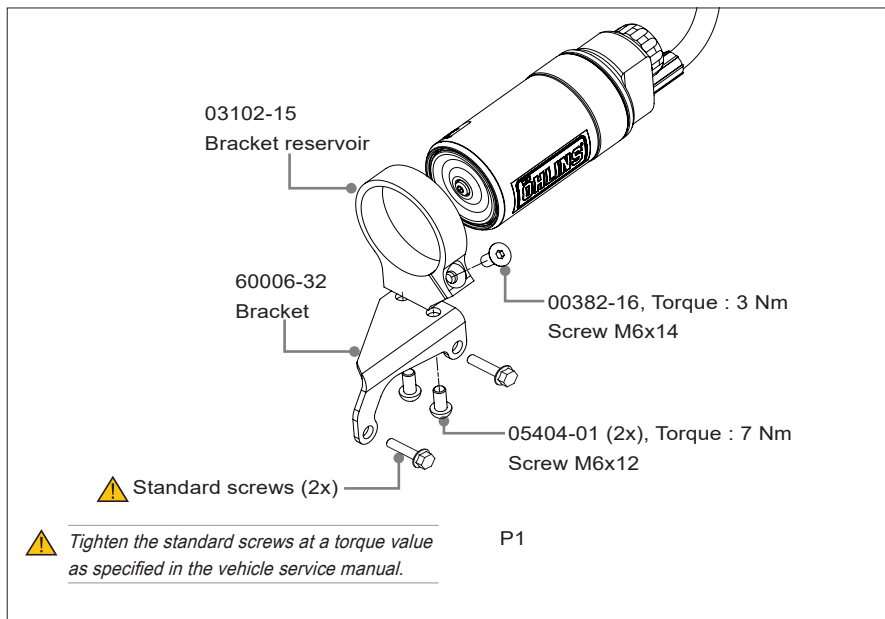
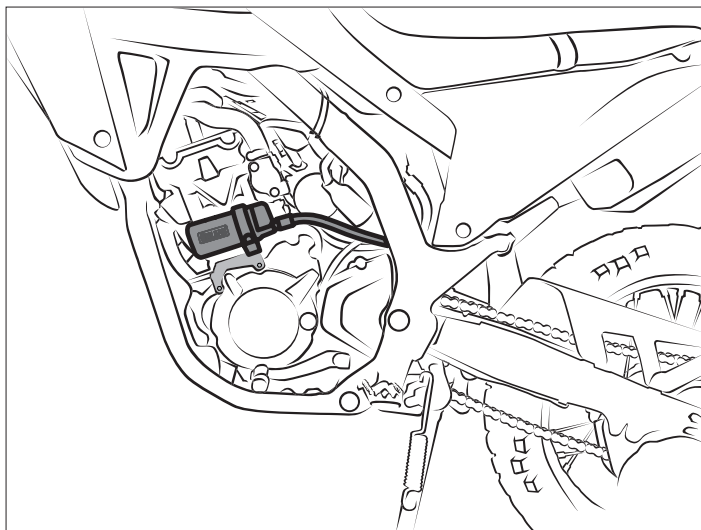

ADJUSTMENTS

⚠ Warning!

Before riding, always make sure that the basic settings made by Öhlins are according to recommended Set-up Data. Read about adjustments and setting up in the Öhlins Owner's Manual before you make any adjustments. Contact an Öhlins dealer if you have any questions about setting up.

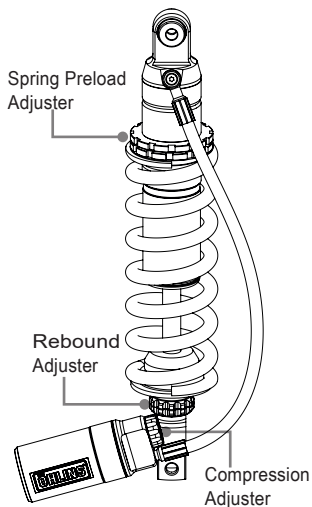

SET-UP DATA

Recommended set-up

Spring Preload.....	12 mm
Compression adjuster	14 Clicks
Rebound adjuster	16 Clicks

Shock absorber data

Length	405.5 mm
Stroke	86 mm

Spring Installed spring

Part No	60011-31
Free spring length...	230 mm
Spring rate.....	95 N/mm
Preload adj.range....	[0-24] mm

👁 Öhlins products are subject to continuous improvement and development, therefore, although these instructions include the most up-to-date information available at the time of printing, minor updates may occur.

To find the latest information contact an Öhlins distributor. Please contact Öhlins if you have any questions regarding the contents in this document.

Part no. MI_HO 129_EN_0
Issued 2021-03-30

© Öhlins Asia Co. Ltd. All rights reserved. Any reprinting or unauthorized use without the written permission of Öhlins Racing AB is prohibited.

Öhlins Asia Co. Ltd
700/937 Moo5, Tambol Nongkhaga,
Amphur Phantong, Chonburi Province
20160 Thailand



www.ohlins.com