

Before installing this product, check the contents of the kit. If anything is missing, please contact an Öhlins dealer.

Kit Contents	Part No.	Pcs.
Shock Absorber	BM678	1
Washer	00153-01	1
Screw MC6S 6x16	01046-01	2
Screw MC6S 8x16	01046-22	1
Bracket	02267-05	1
Bracket	02267-06	1
Adapter	21866-01	1
Öhlins Sticker	00192-01	2
Memo Notes Sticker	01180-01	1
Tie-rap	00231-01	2
Owner's Manual	07242-01	1

Please note that during storage and transportation, especially at high ambient temperature, some of the oil and grease used for assembling may leak and stain the packaging. This is in no way detrimental to the product, wipe off the excessive oil/grease with a cloth.

⚠ Warning!

Before installing this product, read the Öhlins Owner's Manual. The shock absorber is an important part of your vehicle and will affect the stability.

Shock Absorber for BMW R1200 GS ADVENTURE, Rear

BM 678

Mounting Instructions



How to Install

⚠ Warning!

It is advisable to have an Öhlins dealer install the shock absorber.

When installing, read the Vehicle Service Manual.

1

Put the motorcycle on a workstand so that the rear wheel barely touches the ground. The swing arm must be free so that the suspension is unloaded.

⚠ Warning!

Make sure the vehicle is securely supported so

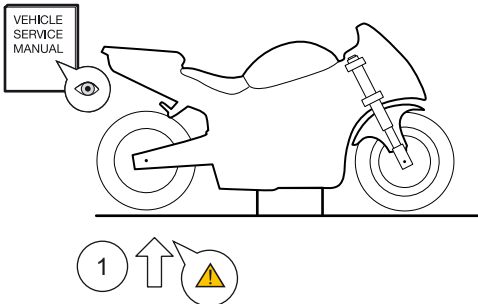

that it will not tip.

2

Unlock the seats. Remove the passenger and driver seats.

3

Loosen the silencer and remove it.

👁 Note!

If the motorcycle has the ESA shock absorber system; Disconnect the electrical connectors from the shock absorber. Make sure that the electrical connectors on the motorcycle are safe from contact with water.

4

Remove the lower shock absorber bolt.

5

Remove the upper shock absorber bolt.

6

Remove the original shock absorber from the left side of the motorcycle.

👁 Note!

Before installing the Öhlins shock absorber clean the vehicle thoroughly.

7

(Only for model year 2006-2007)

Remove the 12V power supply located close to the upper shock absorber attachment point. Attach the supplied adapter (21866-01) to the 12V power supply thread. Install the power supply back to the frame using the original nut.

8

Install the Öhlins shock absorber in the same way as the original unit.

👁 Note!

Lower the motorcycle so that the shock absorber is slightly compressed, before tightening the screws.

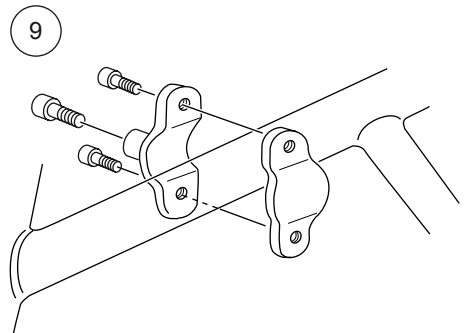

9

Install the preload adjuster brackets to the frame. Use the M6 screws provided in this kit.

10

Install the preload adjuster from the inside. use the M8 bolt and washers provided in this kit. Fasten the hose using the tie-raps.

 **Caution!**

Make sure that the hose runs in soft turns.

11

Reinstall the seats. Make sure that all removed parts are reinstalled in the same way as they were before the installation.

 **Caution!**

Make sure that all screws are tightened to the correct torque and that nothing fouls or restricts movement of the shock absorber when the suspension is fully compressed or extended.

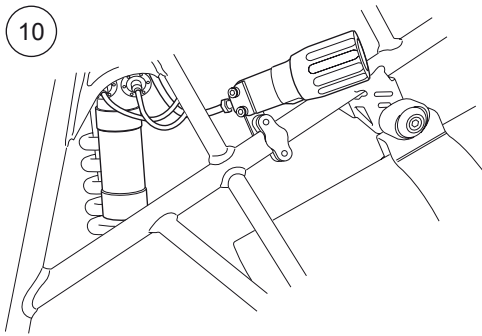

Adjustments

⚠ Warning!

Before riding, always make sure that the basic settings made by Öhlins are according to recommended Set-up Data. Read about adjustments and setting up in the Öhlins Owner's Manual before you make any adjustments. Contact an Öhlins dealer if you have any questions about setting up the shock absorber.

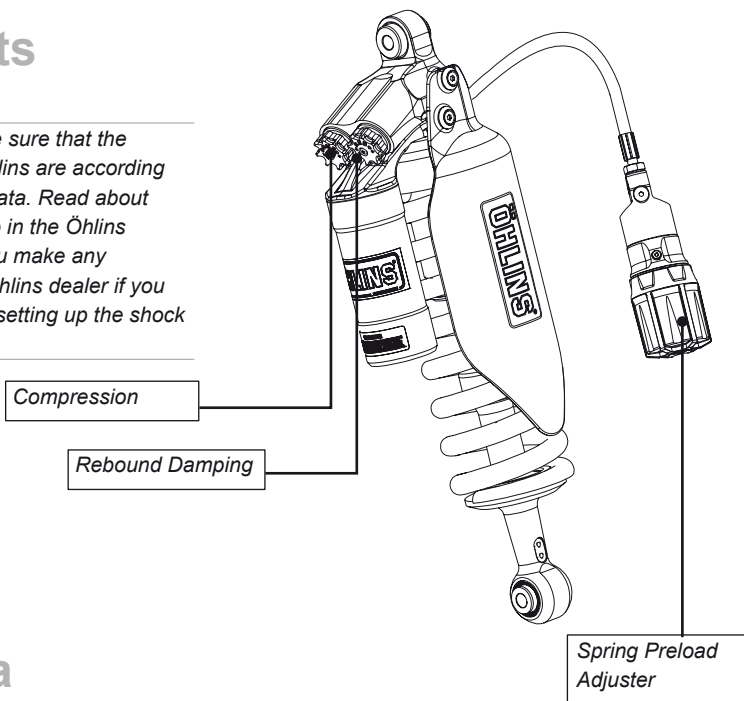

Set-up Data

Recommended set-up

Compression	12 clicks
Rebound	14 clicks
Spring Preload (Adjustment range)	0-10 mm

Free Sag and Ride Height

R1 - R2	34 mm
R1 - R3	69 mm
F1 - F2	41 mm
F1 - F3	54 mm

Shock absorber data

Length	410.5 mm
Stroke	83 mm
Spring	01103-54
Spring, free length	240 mm
Spring rate	140 N/mm

👁 Read about Free Sag and Ride height in the Öhlins Owner's Manual.

👁 Öhlins products are subject to continuous improvement and development, therefore, although these instructions include the most up-to-date information available at the time of printing, minor updates may occur.

To find the latest information contact your Öhlins distributor. Please consult your Öhlins dealer if you have any questions regarding the contents in this document.

Part no. BM678_2
Issued 2013-08-28



© Öhlins Racing AB. All rights reserved. Any reprinting or unauthorized use without the written permission of Öhlins Racing AB is prohibited.

Öhlins Racing AB
Box 722
S-194 27 Upplands Väsby, Sweden
Phone +46 8 590 025 00
fax +46 8 590 025 80



www.ohlins.com