

**⚠ Warning!**

*For off-road use only. Dedicated kits have been designed specifically for track use and should never be used on the streets.*

**👁 Note!**

*Please note that during storage and transport, especially at high ambient temperature, some of the oil and grease used for assembly may leak and stain the packaging. This is in no way detrimental to the product, wipe off the excessive oil or grease with a cloth.*

**👁 Note!**

*Please note that this image is a general representation of the product and may differ slightly from your product.*

**⚠ Warning!**

*Before installing this product, read the Öhlins Owner's manual. The strut/shock absorber is an important part of your vehicle and will effect the stability.*

**Shock absorber for Porsche 911 Carrera and GT3 (996)**

***POU MU10S1***

**Mounting Instructions**



# KIT CONTENTS

Front	
Description	Pcs
ABS cord bracket	2
Dust boot	2
Elastic spacer	2
Lock nut M14	2
Lock ring	4
Plastic spacer - 2562-01	2
Shock absorber - POZ 5i00	2
Main spring - U00159-51	2
Helper spring & adapter - U00159-62	2
Spring platform - 24635-03	2
Upper mounts - U00204-01	2
Upper spring seat - 24637-02	2

Rear	
Description	Pcs
Adjuster	2
Bump rubber	2
Dust boot	2
Elastic spacer	2
Lock nut M12	2
Lock ring	4
Plastic Spacer	2
Screw M6	4
Shock absorber - POZ 6i00	2
Spacer	2
Main spring - U00159-52	2
Helper spring & adapter - U00159-62	2
Spring platform - 24635-03	2
Stabilizer bracket	2
Stop washer	2
Upper spring seat - 25600-02	2
Upper mounts - U00205-01	2

Used for both front and rear	
Description	Pcs
C-spanner	1
C-spanner	1
Owners's manual	1
Sticker set R&T	1

## MOUNTING INSTRUCTIONS

### **⚠ Warning!**

*We strongly recommend to let an Öhlins dealer install this product.*

### **⚠ Warning!**

*If you work with a lifted vehicle, make sure that it is safely supported to prevent it from tipping over.*

### **👁 Note!**

*When you work with this product, see the vehicle service manual for vehicle specific procedures and important data.*

### **👁 Note!**

*Before you install this product check the contents of the kit. If anything is missing, please contact an Öhlins dealer.*

# MOUNTING INSTRUCTIONS

**1**

**Front and rear:**

Remove the original shock absorbers from the vehicle, see the vehicle service manual for correct procedure.

**2**

**Front and rear:**

Remove the damper spring assembly with original upper mount assembly and set aside. These are not reused in the installation of the Öhlins Dedicated system.

**👁 Note!**

*See the vehicle service manual on how to remove the parts.*

**⚠ Warning!**

*The spring is preloaded so take precaution when you remove the spring from the damper.*

**3 Front and rear**

Cut the dust boot:

**Front:** 62 mm from the lower end.

**Rear:** 82 mm from the lower end.

**4 Front and rear**

Assemble the strut/shock absorber, see figures F4 (front) and R4 (rear).

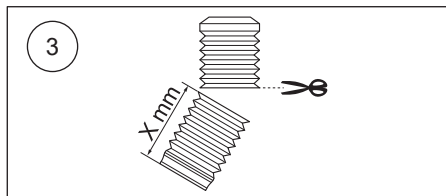

# MOUNTING INSTRUCTIONS

F4

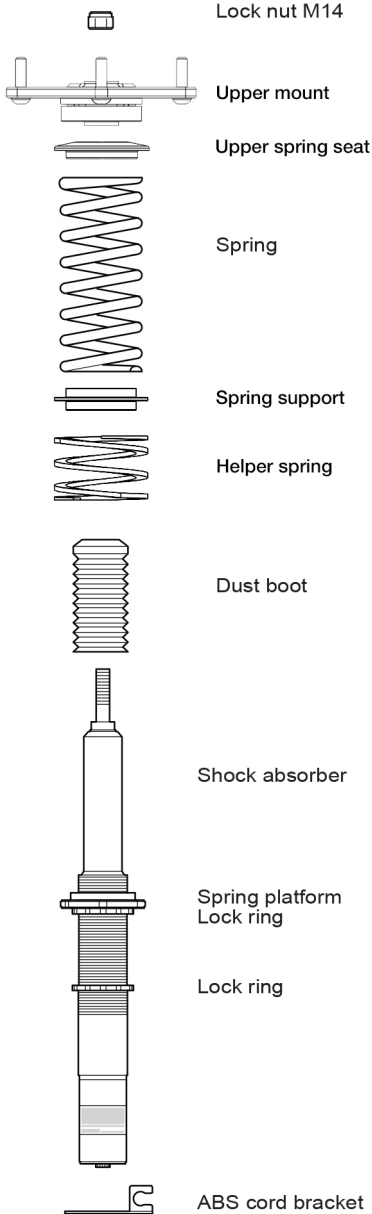

R4

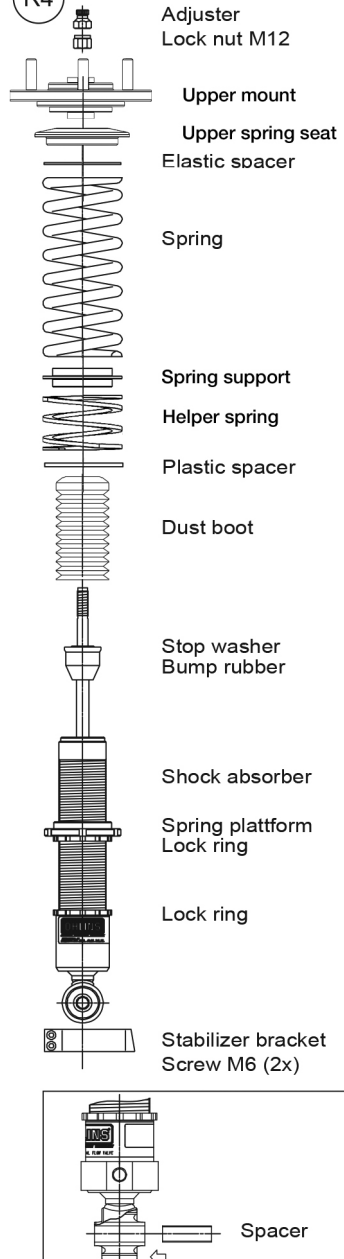

# MOUNTING INSTRUCTIONS

5

## Front and rear:

Set the installation dimensions according to fig F5 and R5. You may need to change these to reach the target height.

### 👁 **Note!**

*After you have installed all shock absorbers/struts you must check and adjust height. See section Adjustments and Setup data.*

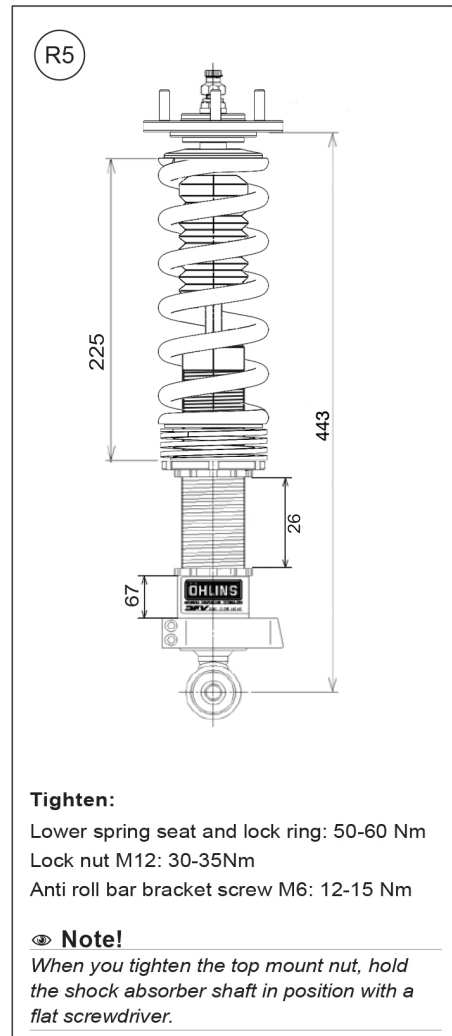
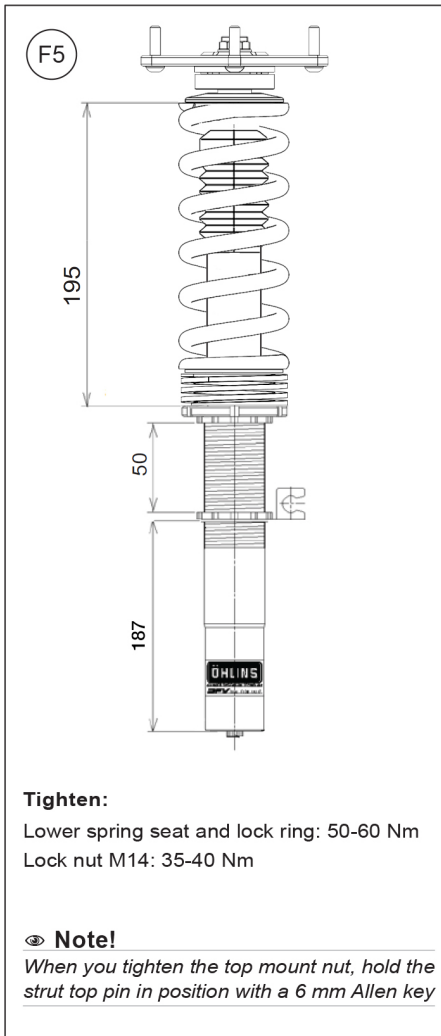

# MOUNTING INSTRUCTIONS

6

**Front:**

Install the Öhlins strut on the vehicle according to the vehicle service manual.

**Rear:**

Install the Öhlins shock absorber on the vehicle according to the vehicle service manual.

**⚠ Caution!**

*Ensure that all screws are tightened to the correct torque and that nothing fouls or restricts movement of the strut/shock absorber when the suspension is fully compressed or extended.*

**👁 Note!**

*Make sure that all removed parts, except the replaced parts, are reinstalled in the same positions as they were before the installation of the Öhlins shock absorbers.*

7

**Rear:**

Position the anti roll bar bracket according to figure R7.

8

**Rear:**

If the car is equipped with the BOSE loud speaker system you will need a wire adjuster.

Part numbers:

24631-01 (1 pc/side)

24632-01 (1 pc/side)

24633-01 (1 pc/side)

24633-02 (1 pc/side)

**👁 Note!**

*Parts for step 8 need to be ordered separately.*

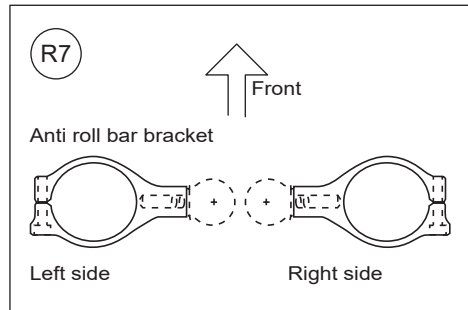

# ADJUSTMENTS

## **⚠ Warning!**

*Before you drive, always make sure that the setup is according to the recommended setup data. Read about adjustments and setting up in the Öhlins Owner's Manual before you make any adjustments. Contact an Öhlins dealer if you have any questions about setting up.*

## **👁 Note!**

*All dimensions are applicable for vehicles with original wheel dimensions.*

## **Set vehicle height**

When the Öhlins dampers are setup according to figures F5 and R5 and installed on the vehicle we recommend to set the height. Below is a short description on how to setup the target height of the car and what the limits for adjustment are:

### **Definitions:**

A; Highest point on fender to ground.

B; Highest point on fender to center of wheel.

B'; Highest point of fender to lower edge of rim.

D; Diameter of rim (measured)

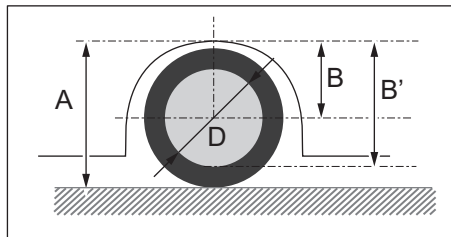

## **Actual vehicle height:**

The target height (B) for your vehicle with the Öhlins dampers installed is:

- front: 330 mm
- rear: 335 mm

To calculate target height (B):

1. Measure the rim (D).
2. Measure from the lowest point of the fender to the lowest edge of the rim and deduct half the diameter of the rim (D).

$$B = B' - D/2$$

If the height needs to be adjusted to reach the target height, change the length of the damper with the lower lock ring on the front damper and by moving the golden cup on the rear damper.

## **👁 Note!**

*Do not adjust outside the recommended range. Tighten to the specified torque after you have adjusted.*

# SETUP DATA

Adjuster settings for Track use		
Front	6	clicks
Rear	7	clicks
Spring		
Spring rate	Front 110 N/mm	
	Rear 150 N/mm	

## Vehicle height

Set the vehicle height with the dampers installed on the vehicle. See instructions in the Owner's Manual.

When adjusting the vehicle height Öhlins recommends making adjustments at the height adjuster, not the spring preload adjuster.

Öhlins products are subject to continuous improvement and development, therefore, although these instructions include the most up-to-date information available at the time of printing, minor updates may occur.

To find the latest information contact an Öhlins distributor. Please contact Öhlins if you have any questions regarding the contents in this document.

Part no. U00250-04\_3  
Issued 2023-04-12

© Öhlins Racing AB. All rights reserved. Any reprinting or unauthorized use without the written permission of Öhlins Racing AB is prohibited.

Öhlins USA INC  
703 S. Grove St. Hendersonville  
NC 28739  
Phone 828-692-4525  
Fax 828-692-0595



[www.ohlins.com](http://www.ohlins.com)