

Kit Contents		
Description	Part No	Pcs
Steering damper	SD20 040	1
Sticker Öhlins	00192-01	2
Tie-rop	00231-01	1
Spacer	02238-12	1
Spacer	02239-04	2
Teflon spacer	02259-01	1
Screw M6×30	05404-07	1
Owner's manual	07261-03	1

Note!

Please note that there can be small differences between your product and the images in these instructions.

Note!

Please note that during storage and transport, especially at high ambient temperature, some of the oil and grease used for assembly may leak and stain the packaging. This will not cause damage to the product, wipe off the excessive oil or grease with a cloth.

Note!

Before you install this product, check the kit contents. If anything is missing, please contact an Öhlins dealer.

Warning!

Before you install this product, read the Öhlins Owner's manual. This product is an important part of the vehicle and the vehicle stability.

Steering damper for Ducati Panigale, Panigale V4

SD20 040

Mounting Instructions



ÖHLINS

MOUNTING INSTRUCTIONS

Warning!

We strongly recommend to let an Öhlins dealer install this product.

Warning!

If you work with a lifted vehicle, make sure that it is safely supported to prevent it from tipping over.

Note!

When you work with this product, see the vehicle service manual for vehicle specific procedures and important data.

Note!

Before you install this product clean the vehicle.

1

Remove the original steering damper according to the vehicle service manual.

2

Install the Öhlins steering damper in the original brackets.

Use the screw (05404-07), sleeve (02239-04) and spacer (02238-12) for the end eye bracket on the handle bar.

Use the original screw, sleeve (02239-04) and the teflon spacer (02259-01) for the frame bracket. Install the teflon spacer between the Öhlins bracket and the sleeve. See figure.

3

Fasten the brake fluid container hose with the tie-rop provided in the kit according to the figure. The hose must not rub against anything between the brake fluid container and the master cylinder since this can cause wear on the hose when the steering damper moves.

Caution!

Make sure that there is no clearance problem when you turn to the left and right end positions. Make sure that the steering damper is not used as a stop.

Caution!

Make sure that you tighten all screws to the correct torque and that nothing fouls or restricts movement of the shock absorber/front fork/steering damper when the suspension is fully compressed or extended.

MOUNTING INSTRUCTIONS

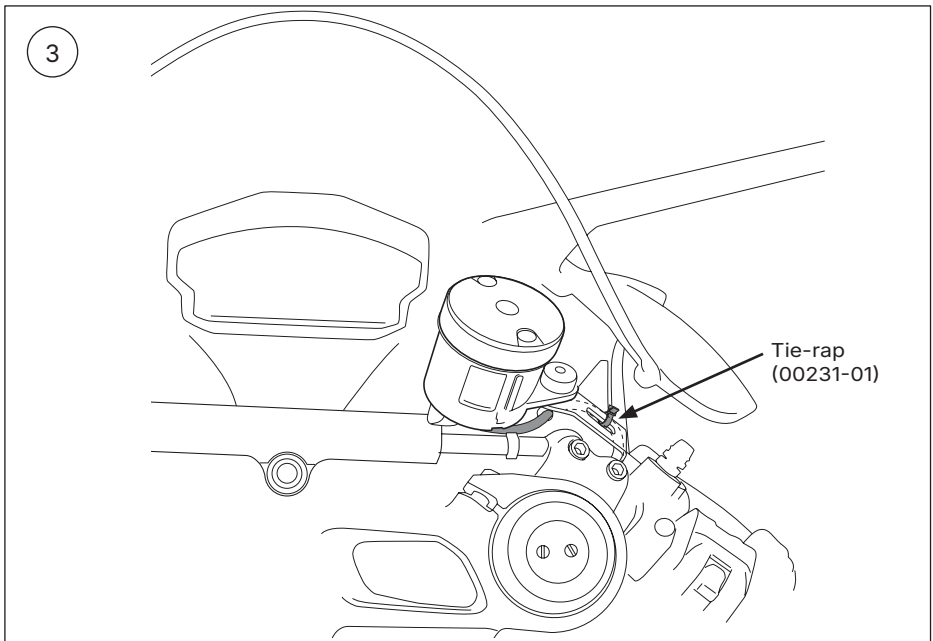
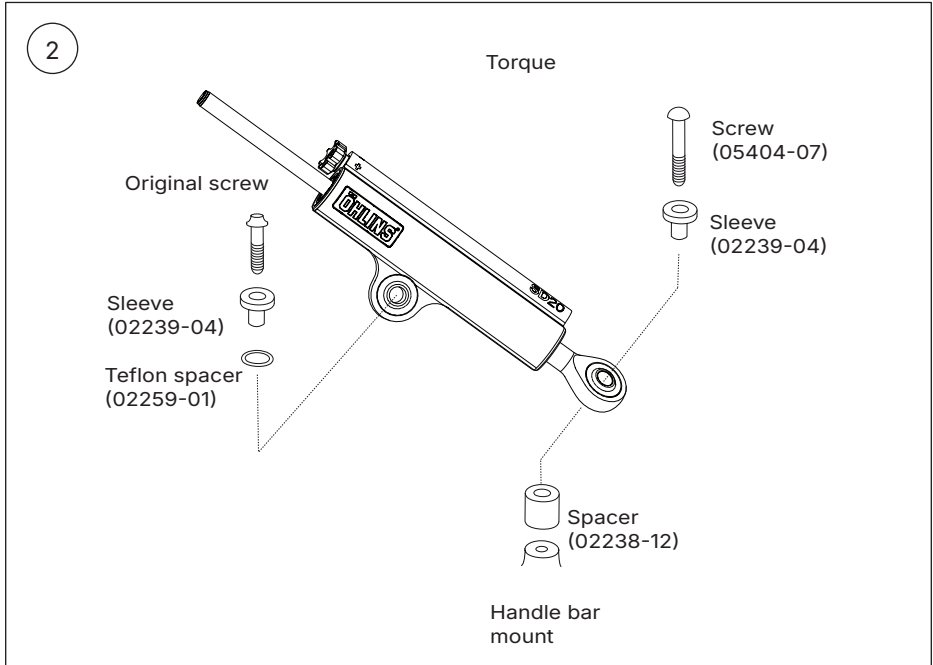

ADJUSTMENTS

⚠ Warning!

Before you ride/drive, always make sure that the setup is according to the recommended setup data. Read about adjustments and setting up in the Öhlins Owner's Manual before you make any adjustments. Contact an Öhlins dealer if you have any questions about setting up.

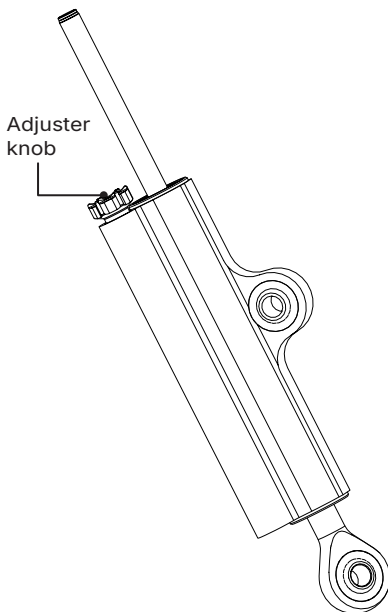

SETUP DATA

Recommended setup	12	clicks
-------------------	----	--------

Öhlins products are subject to continuous improvement and development, therefore, although these instructions include the most up-to-date information available at the time of printing, minor updates may occur.

To find the latest information contact an Öhlins distributor. Please contact Öhlins if you have any questions regarding the contents in this document.

Part no. ML_SD20 040_0
Issued 2025-09-09

© Öhlins Group AB. All rights reserved. Any reprinting or unauthorized use without the written permission of Öhlins Group AB is prohibited.

Öhlins Group AB
Box 722
S-194 27 Upplands Väsby, Sweden
Phone +46 8 590 025 00
fax +46 8 590 025 80

