

Before installing this product, check the contents of the kit. If anything is missing, please contact your nearest Öhlins dealer.

Kit Contents

	Part No.	Pcs.
Shock absorber	YA 053	1
Screw M12x1.25x55	00439-16	1
C-spanner	00710-02	1
Lock nut M12x1.25	01501-01	1
Öhlins Sticker	00192-01	2
Memo Notes Sticker	01180-01	1
Owner's Manual	07241-02	1

⚠ Warning!

Before installing this product, read the Öhlins Owner's Manual. The shock absorber is an important part of your vehicle and may affect the stability of your vehicle.

Please note that during storage and transportation, especially at high ambient temperature, some of the oil and grease used for assembling may leak and stain the packaging. This is in no way detrimental to the product, wipe off the excessive oil/grease with a cloth.

Shock Absorber for Yamaha FJR 1300

YA 053

Mounting Instructions



How to install

⚠ Warning!

It is advisable to have an Öhlins dealer install the shock absorber.

When installing, consult your Vehicle Service Manual.

1

Put the motorcycle on a workstand so that the rear wheel barely touches the ground.

⚠ Warning!

Make sure the vehicle is securely supported so that it will not tip.

2

Remove the sidecases.

3

Remove the seats and the side fairings.

4

Loosen the original spring preload adjuster.

5

Loosen the link arm from the triangle link.

6

Loosen first the lower shock absorber attachment then the upper.

7

Remove the original shock absorber by sliding it downwards.

👁 Note!

Before installing the Öhlins shock absorber clean the vehicle thoroughly.

8

Install the Öhlins shock absorber in position and attach it to the upper bracket. Do not tighten yet.

9

Attach the shock absorber to the lower bracket. Use the supplied bolt (00439-16) and nut (01501-01).

👁 Note!

Lower the motorcycle so that the shock absorber is slightly compressed, before tightening the screws.

10

Tighten the upper and the lower attachments. Fasten the link arm back to the triangle link.

11

Put the fairings and seats back in position

👋 Caution!

Make sure that all screws are tightened to the correct torque and that nothing fouls or restricts movement of the shock absorber when the suspension is fully compressed or extended.

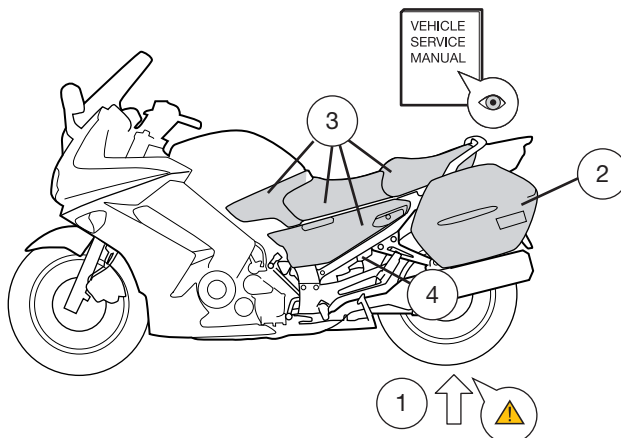

Adjustments

⚠ Warning!

Before riding, always make sure that the basic settings made by Öhlins are according to recommended Set-up Data. Read about adjustments and setting up in the Öhlins Owner's Manual before you make any adjustments. Contact an Öhlins dealer if you have any questions about setting up the shock absorber.

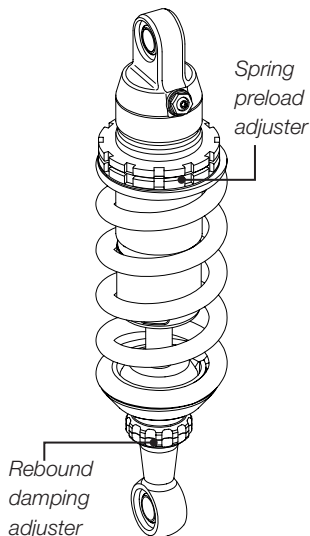

Set-up Data

Recommended set-up

Rebound	16 clicks
Spring Preload	14 mm

Spring

Part No.	Rate
01092-49	130N/mm
Spring free length	170mm

Shock absorber facts

Length	326.5 mm
Stroke	62.5

👁 Öhlins products are subject to continuous improvement and development, therefore, although these instructions include the most up-to-date information available at the time of printing, minor updates may occur.

To find the latest information contact your Öhlins distributor. Please consult your Öhlins dealer if you have any questions regarding the contents in this document.

Part no. YA 053_0
Issued 2010-11-12



© Öhlins Racing AB. All rights reserved. Any reprinting or unauthorized use without the written permission of Öhlins Racing AB is prohibited.

Öhlins Racing AB
Box 722
S-194 27 Upplands Väsby, Sweden
Phone +46 8 590 025 00
fax +46 8 590 025 80



www.ohlins.com