

Kit Contents		
Description	Part No	Pcs
Cartridge kit	FKS 208	1
Preload tube	01460-80	2
Guide ring	21919-01	2
O-ring	00638-96	2
Sticker set Öhlins		1
Owner's manual	07289-01	1

**Note!**

Please note that there can be small differences between your product and the images in these instructions.

**Note!**

Please note that during storage and transport, especially at high ambient temperature, some of the oil and grease used for assembly may leak and stain the packaging. This will not cause damage to the product, wipe off the excessive oil or grease with a cloth.

**Note!**

Before you install this product, check the kit contents. If anything is missing, please contact an Öhlins dealer.

**Warning!**

Before you install this product, read the Öhlins Owner's manual. This product is an important part of the vehicle and the vehicle stability.

## Cartridge kit for Triumph Thruxton

# FKS 208

## Mounting Instructions



# MOUNTING INSTRUCTIONS

## **⚠ Warning!**

*We strongly recommend to let an Öhlins dealer install this product.*

## **⚠ Warning!**

*If you work with a lifted vehicle, make sure that it is safely supported to prevent it from tipping over.*

## **👁 Note!**

*When you work with this product, see the vehicle service manual for vehicle specific procedures and important data.*

## **👁 Note!**

*Before you install this product clean the vehicle.*

<b>Tool</b>	<b>Part no</b>	<b>Size</b>
Pull-up tool	01765-08	
Stopper plate	02810-03	
Wrench (shaft nut)		13 mm
Allen key (bottom bolt)		8 mm
Tool (adjustment housing)		36 mm socket
Tool (adjuster)		14 mm socket
Grease	00146-01/02	100g/400g

# MOUNTING INSTRUCTIONS

## Remove the original front fork

1

Put the motorcycle on a workstand so that the front wheel barely touches the ground.

### **⚠ Warning!**

*Make sure the vehicle is securely supported so that it will not fall over.*

2

Remove the front fender, brake calipers and front wheel.

3

Release the spring preload fully (if present).

4

Note the fork leg position.

5

Loosen the upper triple clamp.

6

Loosen (do not remove) the top cap 1/2 turn.

7

Loosen the lower triple clamp.

8

Remove the front fork legs from the triple clamps.

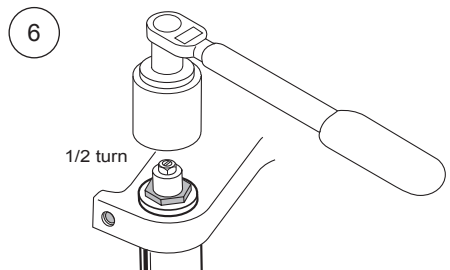
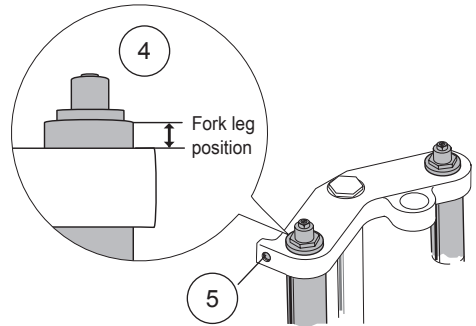
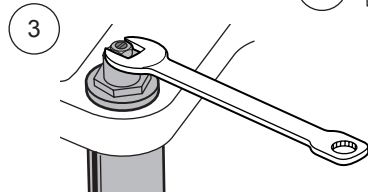
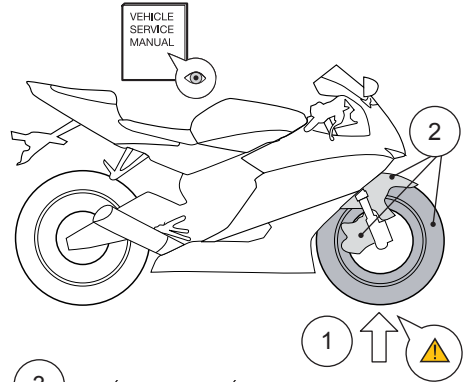

# MOUNTING INSTRUCTIONS

## Remove the original damping system

### **⚠ Warning!**

Spring compression creates a potential danger because of the violent force that loaded springs are capable of.

**Important:** When you remove the top cap push down the top cap and at the same time pull up the inner tube to prevent uncontrolled release.

**1**

Use an appropriate tool to loosen and remove the top cap from the inner tube. Important: When you remove the top cap push down the top cap and at the same time pull up the inner tube to prevent uncontrolled release.

**2**

Remove the preload tube, washer and the main spring.

### **👁 Note!**

When you work with the fork leg, make sure that the inner tube (A) is at lowest position to keep the oil lock sleeve (B) correctly positioned inside the inner tube.

**3**

Drain the fork leg from oil.

**4**

Use a 8 mm Allen key to remove the bottom bolt.

**5**

Remove the damping rod from the fork leg. Do not remove the top out spring.

### **⚠ Warning!**

Make sure the original top out spring is not removed.

### **👁 Note!**

Carefully remove the damper rod to make sure that the spring inside the oil lock sleeve is correctly positioned.

If the spring (A) inside the oil lock sleeve is removed, refer to vehicle service manual for reinstallation.

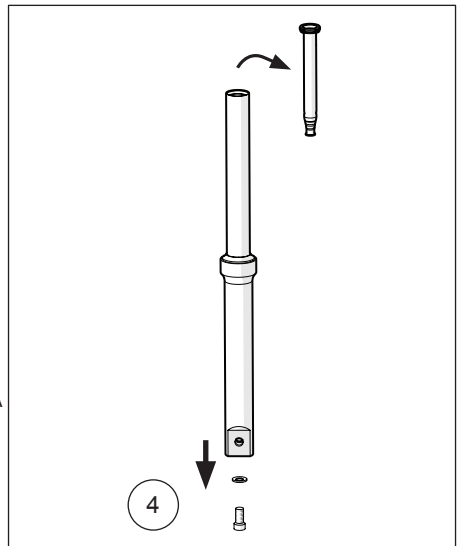
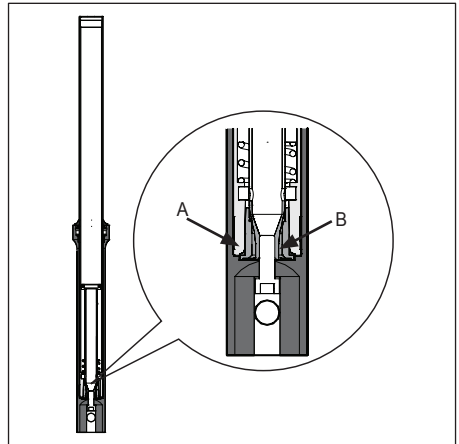
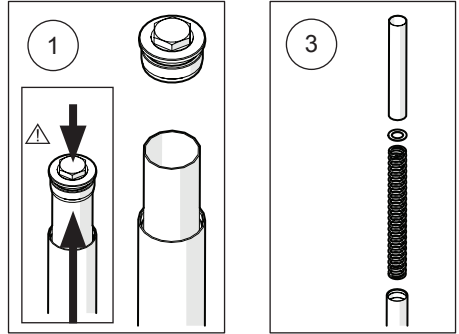
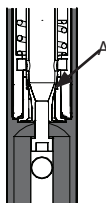

# MOUNTING INSTRUCTIONS

## Install the Öhlins cartridge kit

### ⚠ Caution!

Do not mix the parts. Work with only one fork leg at a time.

### ⚠ Caution!

The front fork kit consists of one compression cartridge and one rebound cartridge.

### Important:

- Install the cartridge marked "Reb" (Rebound) in the right side fork leg.
- Install the cartridge marked "Comp" (Compression) in the left side fork leg.

1

Remove the top cap from the shaft.

2

Adjust the shaft nut as far up as possible on the shaft, make sure to leave enough threads on the shaft to install the pull up tool.

3

Install the pull up tool (01765-08) on the shaft. Tighten by hand.

### ⚠ Caution!

Keep the fork leg in a vertical position during the installation procedure.

4

Make sure that the oil lock sleeve (A) and top out spring (B) is in correct position.

### ⚠ Warning!

Make sure the top out spring is in correct position.

5

Put the cartridge in the fork leg.

6

Make sure that the cartridge is in the lowest position. Refer to vehicle service manual for threadlocker and tightening torque. Install bottom bolt and washer. Use tool 8 mm allen key to tighten bottom bolt.

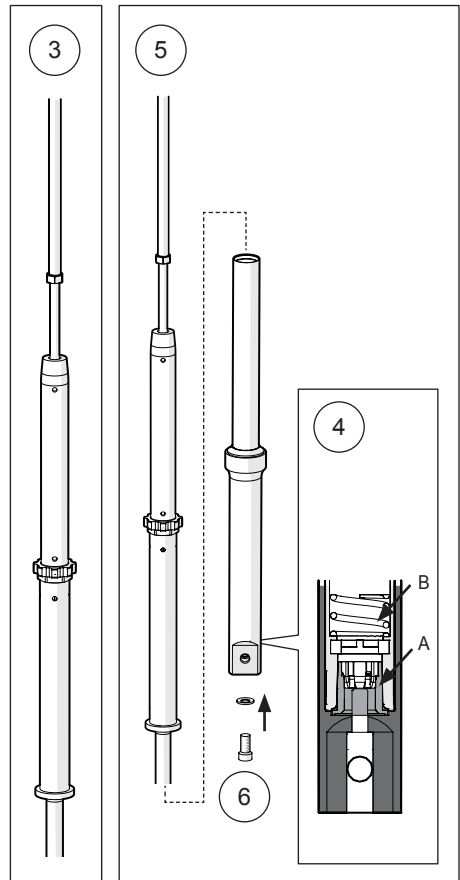
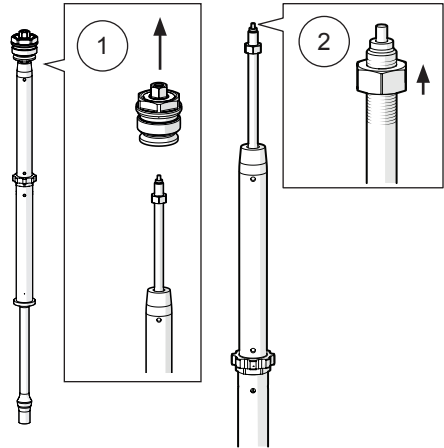

# MOUNTING INSTRUCTIONS

7

Pour Öhlins front fork fluid (01309-XX) in the fork leg.

If the oil level comes near the upper end of the inner tube, move the steel tube up and down to release air trapped inside the fork leg.

8

Pull the inner tube up and down approximately 10 times to release all air trapped inside the fork leg.

9

Pull the shaft up and down approximately 10 times to release all air trapped inside the cartridge.

10

Make sure that the shaft, guide sleeve and inner tube is in the lowest position. Set the oil level according to chapter "Setup data".

11

Make sure that the mark on the main spring is up. Install main spring (A), guide ring (B) and preload tube (C).

**Note!**

*Make sure that the guide ring (B) is positioned correctly.*

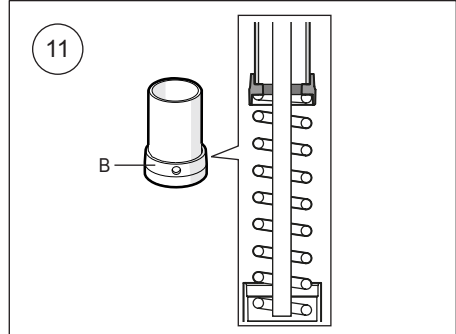
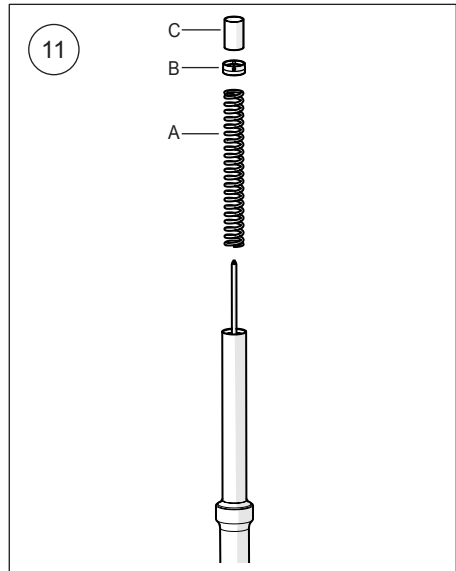
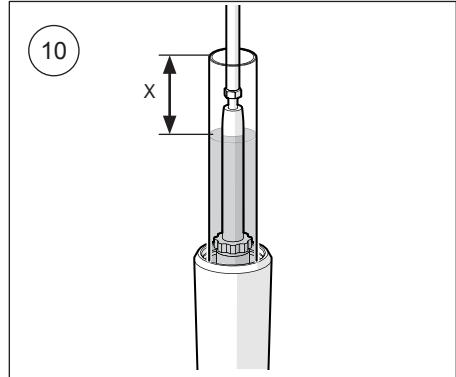

# MOUNTING INSTRUCTIONS

12

Push down the preload tube and at the same time pull up the shaft. Carefully insert the stopper plate tool (02810-03) below the shaft nut.

## **⚠ Warning!**

*Spring compression creates a potential danger because of the violent force that loaded springs are capable of. Beware of this when you adjust the shaft nut.*

13

Remove the pull up tool from the shaft.

14

Use a 13 mm wrench to adjust the shaft nut until bottomed. Make sure that the stopper plate tool stays in place.

15

Install the o-ring on the top cap. Apply grease (00146-01/02) on the o-ring and on the top cap thread.

## **⚠ Warning!**

*Make sure that the compression and rebound adjusters are fully open counter clockwise before installing the top cap.*

16

Install the top cap on the shaft until stop.

## **👁 Note!**

*Make sure that the top cap is completely bottomed.*

17

Use a tool 14 mm socket for the preload adjuster and a 13 mm wrench to tighten the shaft nut to the top cap. Tighten the shaft nut to 12 Nm.

18

Push down the preload tube and carefully remove the stopper plate tool. Make sure that the preload tube is correctly installed in the preload socket.

19

Pull up the inner tube and at the same time push down the top cap. Use tool 36 mm socket to tighten the top cap to the inner tube. Tighten the top cap to 10 Nm.

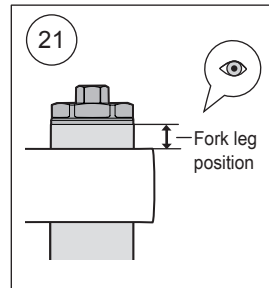
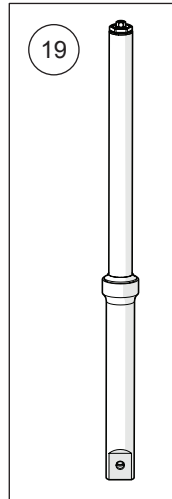
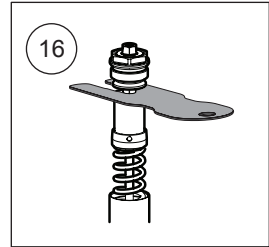
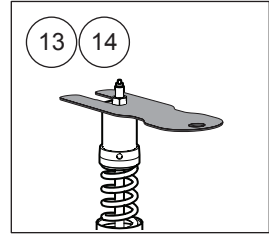
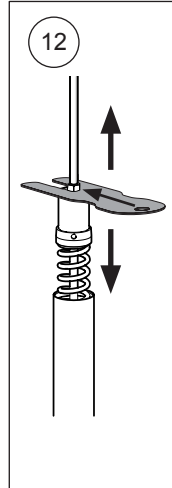

20

Set the compression, rebound and preload adjusters according to setup data.

21

Install the front fork in the vehicle at the fork leg position according to setup data. See the vehicle service manual for instructions.

## **⚠ Warning!**

*Make sure to install all removed parts in the same positions as they were before the installation of the ohlins cartridge kit.*

# SETUP DATA

Compression adjustment	12	clicks
Rebound adjustment	12	clicks
Öhlins Front fork fluid	01309-xx	
Oil level	160	mm
Fork leg position	Standard	

## SPRING GUIDE

Make sure you choose the correct spring for your rider weight, driving style and preferences. Contact an authorized Öhlins service center for advice.

Rider weight (no gear) [Kg]	40	50	60	70	80	90	100
Spring rate [N/mm]	8.0	8.0	8.5	8.5	9.0	9.0	9.5
Pre load [mm]	6	7	7	8	8	9	9
Spring part number	08429-80	08429-80	08429-85	08429-85	08429-90	08429-90	08429-95

### 👁 **Note!**

*Springs are packed in pairs.*

Öhlins products are subject to continuous improvement and development, therefore, although these instructions include the most up-to-date information available at the time of printing, minor updates may occur.

To find the latest information contact an Öhlins distributor. Please contact Öhlins if you have any questions regarding the contents in this document.

Part no. MI\_FKS208\_1  
Issued 2017-01-01

© Öhlins Racing AB. All rights reserved. Any reprinting or unauthorized use without the written permission of Öhlins Racing AB is prohibited.

Öhlins Racing AB  
Box 722  
S-194 27 Upplands Väsby, Sweden  
Phone +46 8 590 025 00  
fax +46 8 590 025 80



[www.ohlins.com](http://www.ohlins.com)