

### **Note!**

Before installing this product, check the contents of the kit. If anything is missing, please contact an Ohlins dealer

### **Kit Contents**

Description	Part No	Pcs
Shock absorber	HO545	1
Washer 15/28/2	60426-02	1
Screw M8x35	00432-01	1
Sticker Öhlins	00192-01	2
Sticker Öhlins	01185-01	2
Sticker Öhlins	01185-04	2
C-spanner	60710-01	2
Owner's manual	07241-02	1

### **Kit for Honda Click125-2013**

Spring	60360-09	1
Sleeve 10/13.9/20	61123-07	1

### **Index**

### **Page**

Click125 2015	2-10
Click125 2013	11-13

### **Note!**

Please note that this image is a general representation of the product and may differ slightly from your product.

### **Note!**

Please note that during storage and transportation, especially at high ambient temperature, some of the oil and grease used for assembling may leak and stain the packaging. This is in no way detrimental to the product, wipe off the excessive oil/grease with a cloth.

### **Warning!**

Before installing this product, read the Öhlins Owner's Manual. The shock absorber is an important part of your vehicle and will affect the stability.

## **Shock Absorber for Honda Click125-2015/2013**

# **HO545**

## **Mounting Instructions**

# MOUNTING INSTRUCTIONS

**⚠ Warning!**

*It is advisable to have an Öhlins dealer install the shock absorber.*

**⚠ Warning!**

*If working on a raised vehicle, ensure it is securely supported so that it will not tip over.*

**👁 Note!**

*Before mounting this product clean the vehicle thoroughly.*

**👁 Note!**

*When working on this product, always see the Vehicle Service Manual for vehicle specific procedures and important data.*

## HONDA Click 2015

1

Put the motorcycle on center stand so that the rear wheel barely touches the ground. Make sure the motorcycle is in a stable position.

1

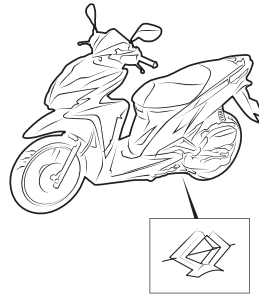

2

Open the seat and remove the grab bar by loosening the 3 bolts

2

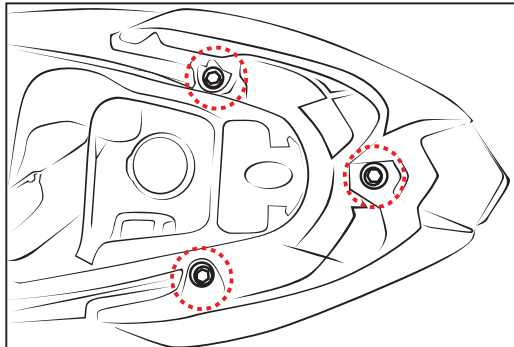
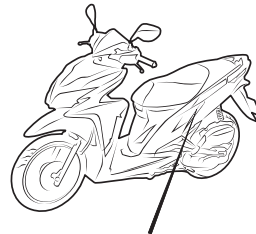

# MOUNTING INSTRUCTIONS

3

Dismount the center storage box by loosening 5 screws and 1 clip, then remove the seat and storage cover of the bike.

3

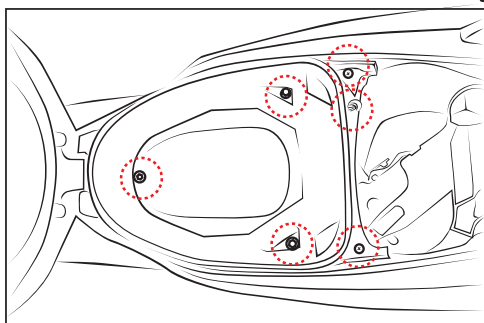
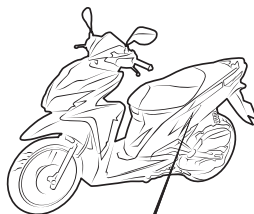

4

Remove the tail light by loosening the 2 top cover screws

4

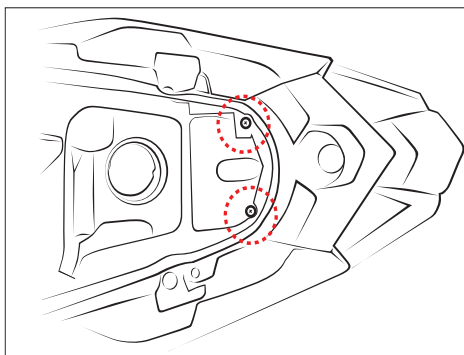
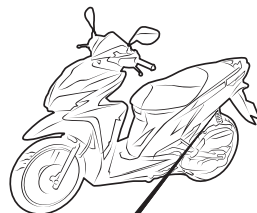

# MOUNTING INSTRUCTIONS

5

Remove the 2 tail light cover screws.

5

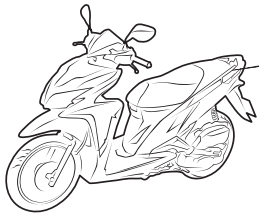

6

Unplug the light wiring connector in order to remove the tail light cover.

6

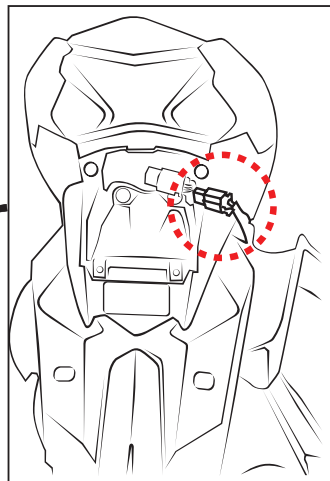
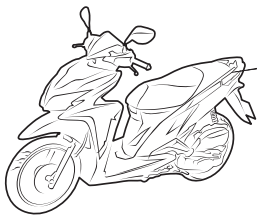

# MOUNTING INSTRUCTIONS

7

Loosen 2 screws then remove the seat lower plastic cover.

7

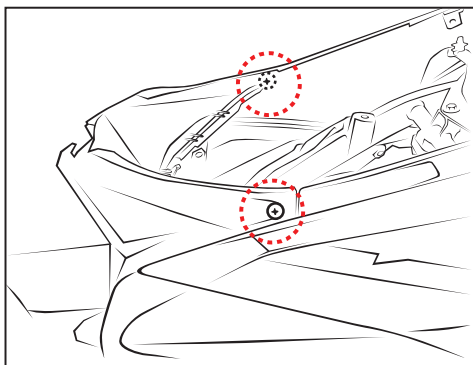
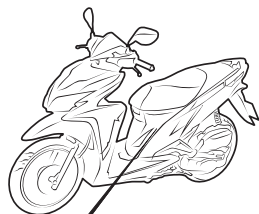

8

Remove the plastic fairings together with the lamp :

8-1

8-1 Remove the right and left plastic push clip.

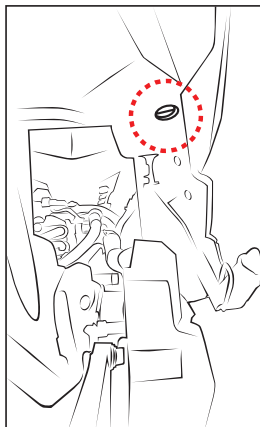
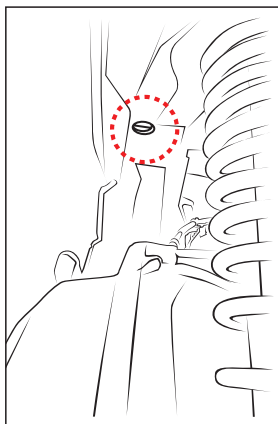
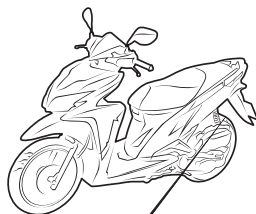

# MOUNTING INSTRUCTIONS

8-2 Remove the 2 screws (left and right fearing)

8-2

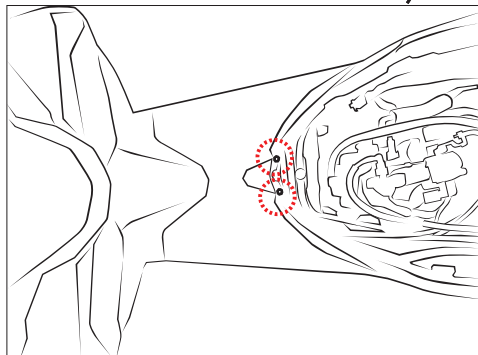
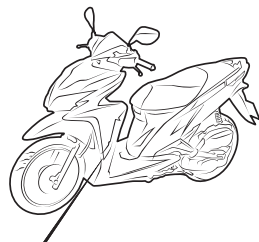

8-3 Remove 2 screws (left and right),(under the fearing)

8-3

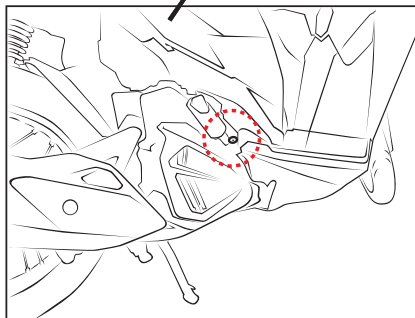
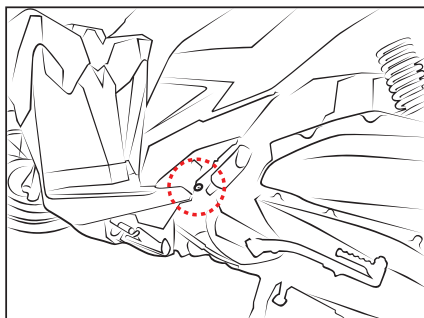
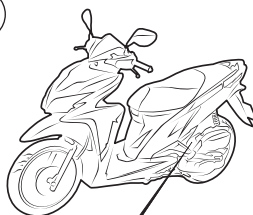

# MOUNTING INSTRUCTIONS

8-4 Remove 2 screws (left and right), under the rear light and unplug the rear light wiring.

8-4

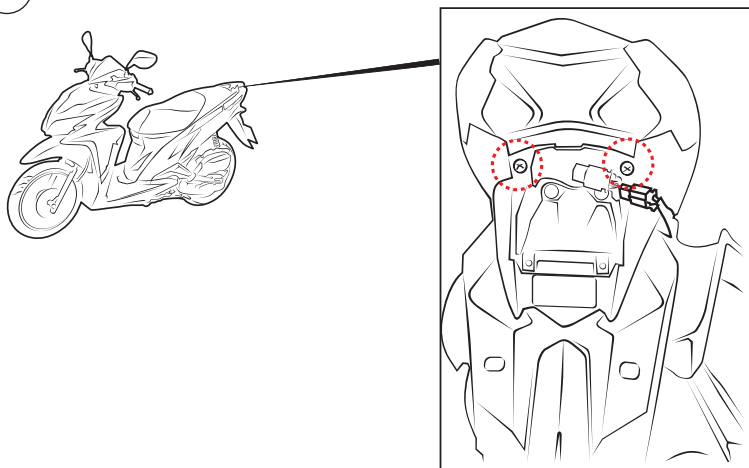

9

Move the fuel tank by loosening 5 screws in order to access to the top mounting screw of the shock absorber.

9

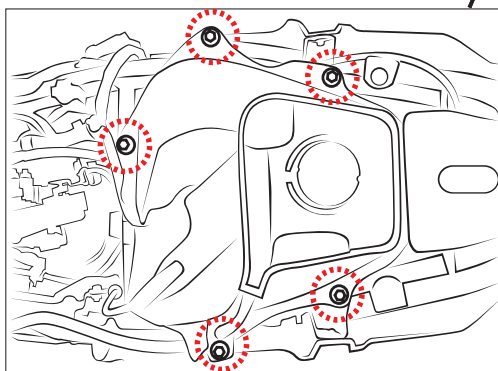
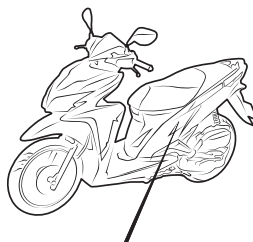

# MOUNTING INSTRUCTIONS

10

Remove the top mounting nut together with the washer.

10

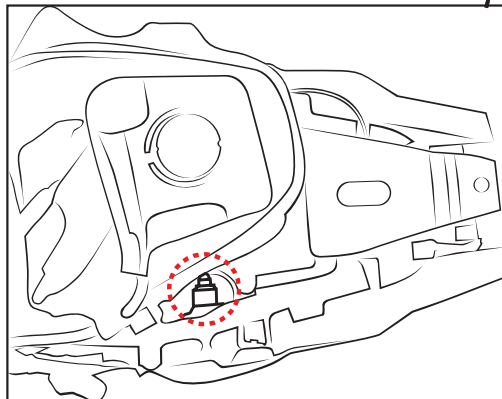
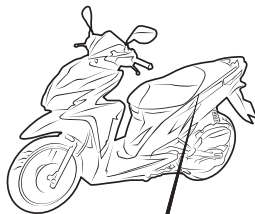

11

Remove the bottom screw then remove the standard shock absorber.

11

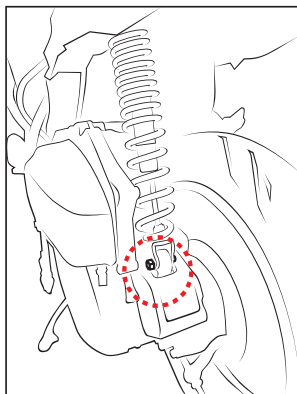
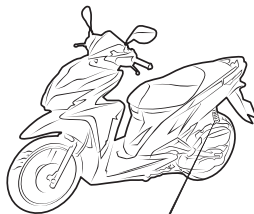

# MOUNTING INSTRUCTIONS

12

Release the rear fender by :

12-1 Loosening 2 lateral screws.

12-1

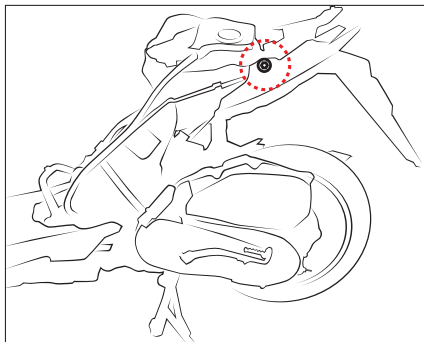
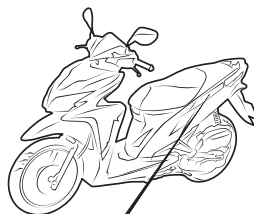

12-2. Remove 2 rear screws.

in order to install the Öhlins shock absorber.

12-2

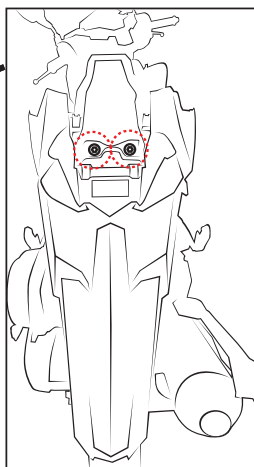
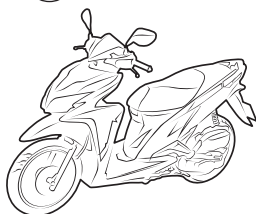

# MOUNTING INSTRUCTIONS

## 13.

Install the Öhlins shock absorber :

- Top nut : Insert in position the shock absorber, then the washer 60426-02, then the standard washer, and finally tighten the nut.

- Bottom screw : Fix in position the shock absorber by using the screw 00432-01.

Tighten at the specific torque value as per Honda service manual and reverse all procedures.

13

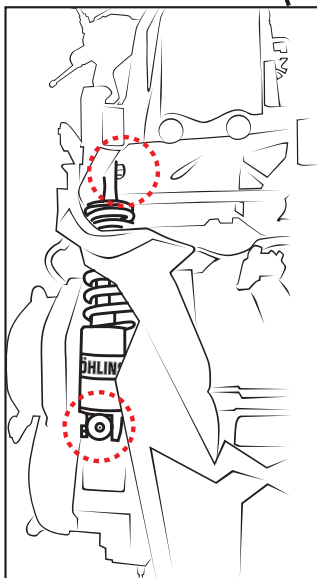
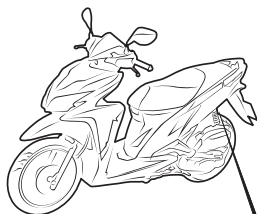

# MOUNTING INSTRUCTIONS

## HONDA Click 2013

- 1  
Open up seat and remove bar end by loosening 3 bolts with 12 mm socket wrench.

1

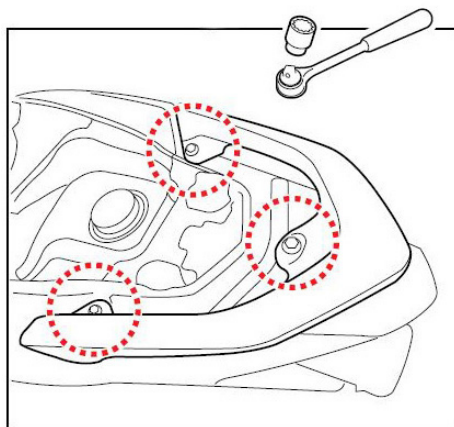
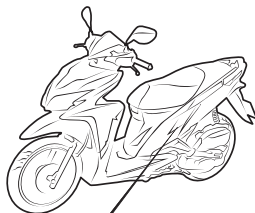

2.  
Dismount center storage box by loosening 2 screws with screw driver (+)

2

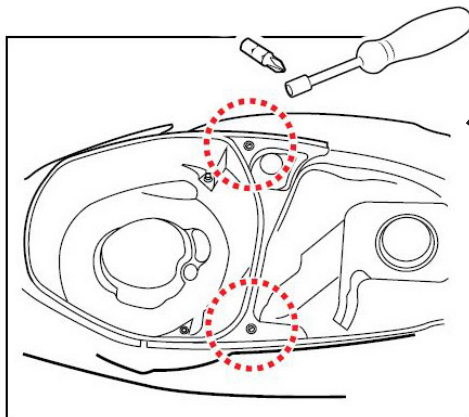
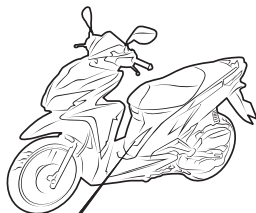

# MOUNTING INSTRUCTIONS

3.  
Remove seat panel by loosening 1 screw  
both LH/RH with screw driver (+).

3

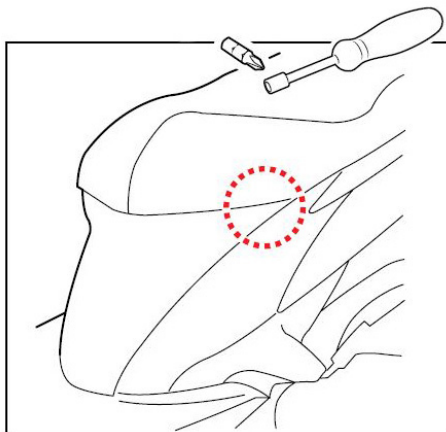
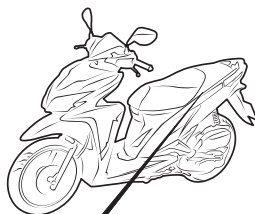

4.  
Loosening 4 screws by screw driver (+) and  
remove plastic clip, in order to open up more  
space for shock absorber dismounting.

4

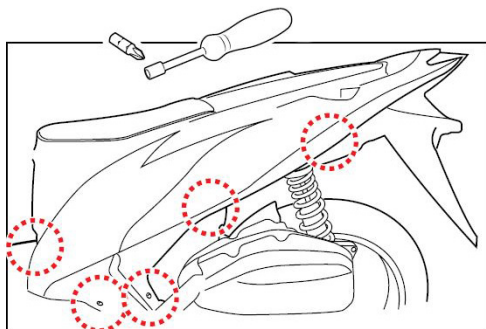
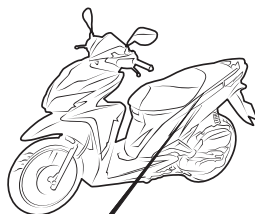

# MOUNTING INSTRUCTIONS

5.

Remove the original shock loosening bolt 12 mm (Bottom) and 14 mm (Top) by socket wrench.

5

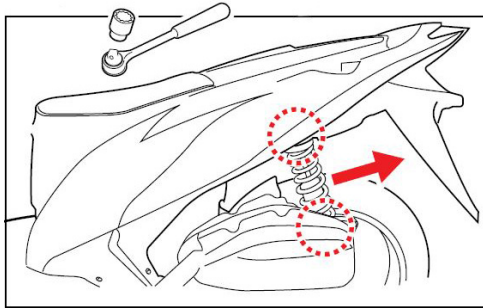
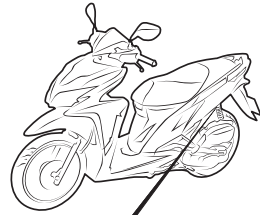

6.

Install the Öhlins shock absorber :

- Top : Fit the sleeve 61123-07 into the end-eye bushing and fix it by tightening the nut
- Bottom screw : Fix in position the shock absorber by using the screw 00432-01.

Tighten at the specific torque value as per Honda service manual and reverse all procedures.

6

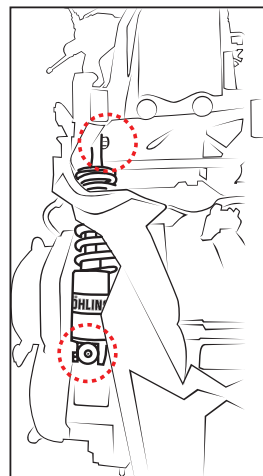
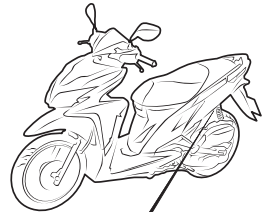

## **Note!**

Lower the vehicle so that the suspension is slightly compressed before tightening the screws.

## **Caution!**

Ensure that all screws are tightened to the correct torque and that nothing fouls or restricts movement of the shock absorber when the suspension is fully compressed or extended.





# ADJUSTMENTS

## ⚠ Warning!

Before riding, always make sure that the basic settings made by Öhlins are according to recommended Set-up Data. Read about adjustments and setting up in the Öhlins Owner's Manual before you make any adjustments. Contact an Öhlins dealer if you have any questions about setting up.

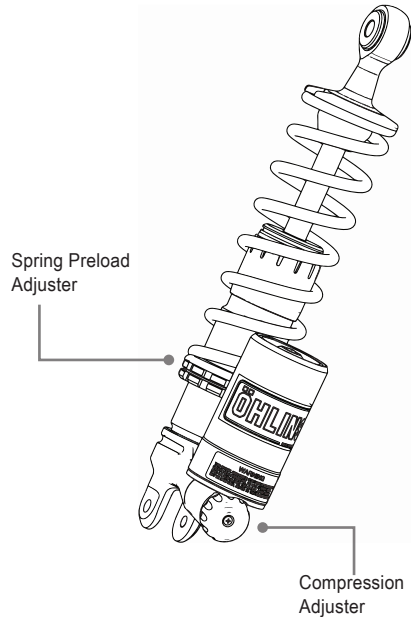

# SET-UP DATA

## Recommended set-up : Click 2015/2013

Spring Preload ..... 5 mm  
Compression adjuster .... 16 Clicks

## Shock absorber data : Click 2015/2013

Length ..... 328 mm  
Stroke ..... 86 mm

## Spring

Part No .....	60360-08	60360-09
Free spring length .....	200 mm	200 mm
Spring rate.....	prog. 31-35 N/mm	prog.22-40 N/mm
Preload adj. range.....	[0-17] mm.	[0-19] mm.

👁 Öhlins products are subject to continuous improvement and development, therefore, although these instructions include the most up-to-date information available at the time of printing, minor updates may occur.

To find the latest information contact an Öhlins distributor. Please contact Öhlins if you have any questions regarding the contents in this document.

Part no. MI\_HO545\_EN\_0  
Issued 2016-02-15

© Öhlins Racing AB. All rights reserved. Any reprinting or unauthorized use without the written permission of Öhlins Racing AB is prohibited.

Öhlins Racing AB  
Box 722  
SE-194 27 Upplands Väsby, Sweden  
Phone +46 8 590 025 00  
fax +46 8 590 025 80



[www.ohlins.com](http://www.ohlins.com)