

Note!

Please note that there can be small differences between your product and the images in these instructions.

Note!

Please note that during storage and transport, especially at high ambient temperature, some of the oil and grease used for assembly may leak and stain the packaging. This will not cause damage to the product, wipe off the excessive oil or grease with a cloth.

Kit Contents		
Description	Part No	Pcs
Cartridge kit	FGK 247	1
O-ring	00576-02	2
Sticker set Öhlins		1
Owner's manual	07284-01	1

Note!

Before you install this product, check the kit contents. If anything is missing, please contact an Öhlins dealer.

Warning!

Before you install this product, read the Öhlins Owner's manual. This product is an important part of the vehicle and the vehicle stability.

Front fork Kit for Yamaha YZF-R7

FGK 247

Mounting Instructions



ÖHLINS

MOUNTING INSTRUCTIONS

⚠ Warning!

We strongly recommend to let an Öhlins dealer install this product.

⚠ Warning!

If you work with a lifted vehicle, make sure that it is safely supported to prevent it from tipping over.

👁 Note!

When you work with this product, see the vehicle service manual for vehicle specific procedures and important data.

👁 Note!

Before you install this product clean the vehicle.

⚠ Warning!

Spring compression creates a potential danger because of the violent force that loaded springs are capable of. Beware of this when you work with the front fork.

Tool	Part no	Applies	Size
Vehicle service manual			
Torque wrench 10-40 Nm		Torque	
Hex key		Compression and rebound adjuster	3 mm
Extended hex key		Cylinder tube assembly	17 mm
Socket		Main preload adjuster	14 mm
Wrench		Spring support	19 mm
Suspension fluid	01309-xx		
Grease	00146-01		100 g
Shaft extension tool	01765-03		
Seal head tool	01797-07		
Top cap tool	00797-08		

MOUNTING INSTRUCTIONS

1 Remove original front fork

Note!

The following procedure applies to both front fork legs.

1.1

Put the motorcycle on a workstand so that the front wheel barely touches the ground.

Warning!

Make sure the vehicle is securely supported so that it will not fall over.

1.2

Remove front fender, brake calipers, speed sensor (if present) and front wheel.

1.3

Release main spring preload fully (if present).

1.4

Note front fork leg position.

1.5

Loosen upper triple clamp.

1.6

Loosen (do not remove) top cap ½ turn.

1.7

Loosen lower triple clamp.

1.8

Remove front fork legs from triple clamps.

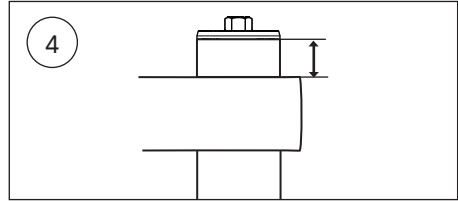

MOUNTING INSTRUCTIONS

2 Disassemble original front fork

Note!

The following procedure applies to both front fork legs.

2.1

Remove top cap from outer tube.

2.2

Slide outer tube down until it stops.

2.3

Remove top cap from shaft according to instructions in the vehicle service manual.

2.4

Remove main spring and associated parts according to instructions in the vehicle service manual.

2.5

Drain front fork leg from suspension fluid.

2.6

Remove cartridge from front fork leg according to instructions in the vehicle service manual.

MOUNTING INSTRUCTIONS

3 Install front fork kit

⚠ Caution!

Work with only one fork leg at a time. Do not mix the parts.

⚠ Caution!

The front fork kit is divided into one compression cartridge and one rebound cartridge. Important:

- Install the cartridge marked "Reb" (Rebound) in the right side fork leg.
- Install the cartridge marked "Comp" (Compression) in the left side fork leg.

3.1

Remove top cap (A), spring support (B) and preload tube and guide ring (C).

3.2

Remove the cylinder tube from the cartridge.

⚠ Caution!

Be careful not to damage the piston ring.

3.3

Put the cylinder tube carefully into the fork leg. Tighten the cylinder tube's adaptor to the bottom screw using an extended 17 mm allen key at the bottom screw. See the vehicle service manual for recommended thread locking fluid and tightening torque.

⚠ Caution!

Be careful not to damage the inside of the cylinder tube when tightening with the extended allen key.

3.4

Pour 0,5 litre Öhlins Front Fork fluid into the fork leg.

3.5

Put the cartridge carefully in the fork leg. Tighten it to the cylinder tube. Use tool 01797-07, and at the same time, hold the bottom screw in place using an appropriate tool. Apply red grease on the seal head's thread. Torque 20 Nm.

⚠ Caution!

Make sure that the piston ring is in its correct position and be careful not to damage it.

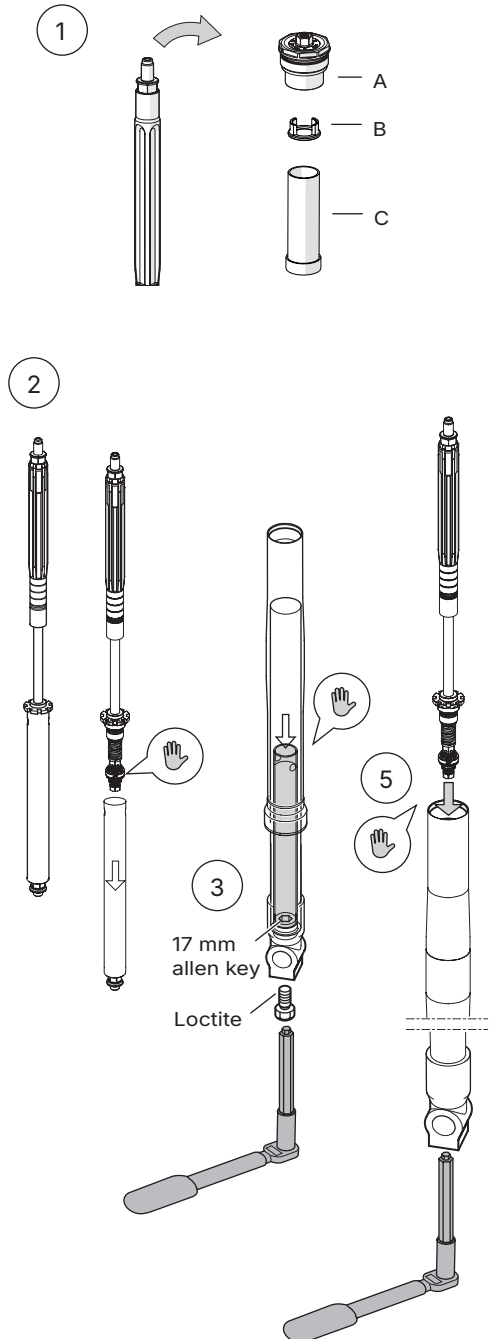

MOUNTING INSTRUCTIONS

3.6

Open the compression and the rebound adjuster fully. Install the top cap directly to the shaft extension (No spring or preload tube). Pull up the outer tube and tighten it to the top cap. Handtighten only.

3.7

Pump out all air from the cartridge by pulling the outer tube up and down 10-15 times.

3.8

Remove the top cap from the fork leg.

3.9

Make sure the shaft assembly is in the bottom of the fork leg and that the outer tube is in its bottom position. Measure the oil level with a ruler. See set-up data and oil level-force diagram in this folder.

3.10

Install shaft extension tool on top of shaft extension. Install main spring with the marking up (A), preload tube and guide ring (B) and spring support (C) over shaft extension tool.

[01765-03 shaft extension tool]

3.11

Pull up the shaft assembly and grab the spring support with a 19 mm wrench.

3.12

Install o-ring on top cap. Apply grease on o-ring and thread.

[00576-02 o-ring]

[00146-01 grease]

3.13

Make sure that the comp/rebound adjusters are fully open before installing the top cap. Remove the pull-up tool and install the top cap to the shaft extensioner. Torque 20 Nm.

3.14

Pull up the outer tube. Make sure the fork leg is in a fully extended position. Use tool 00797-08 to tighten the top cap to the outer tube. Torque 10 Nm.

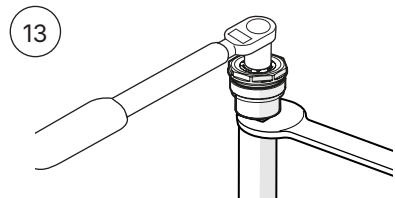
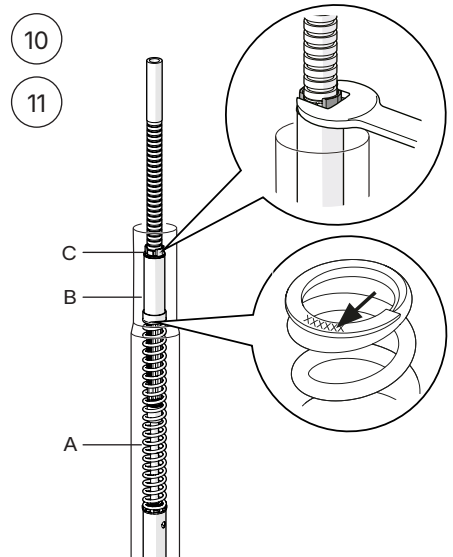
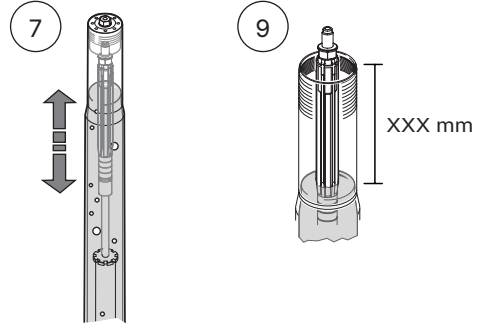

MOUNTING INSTRUCTIONS

3.15

Set the spring preload, rebound and compression adjusters according to adjustments and set-up data in this manual.

3.16

Install the front fork legs into the triple clamps at the position recommended in set-up data (Fork leg position).

Tightening torque: According to your vehicle service manual.

Note!

Measure the fork leg position from the upper triple clamp to the top of the outer tube.

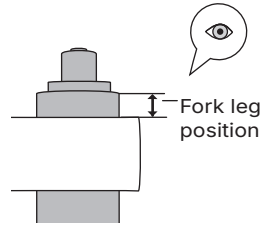

SETUP DATA

Recommended setup

Compression adjustment	12	clicks
Rebound adjustment	12	clicks
Suspension fluid level	170	mm
Minimum suspension fluid level	267	mm
Suspension fluid part number	01309-xx	
Front fork leg position	Standard	

MAIN SPRING GUIDE

Make sure you choose the correct main spring for your rider weight, driving style and preferences. Below you find a general recommendation of main spring rate for your weight. Contact an authorized Öhlins service center for advice.

👁 Note!

Only 08423-xx main springs are packed in pairs.

FGK 247 Yamaha YZF-R7

Rider weight [kg]	50	60	70	80	90	100	110
Spring rate [N/mm]	8.5	9	9	9.5	9.5	10	10
Preload [mm]	7	6	8	8	10	9	11
Part number (pair)	08423-85	08423-90	08423-90	08423-95	08423-95	08423-10	08423-10

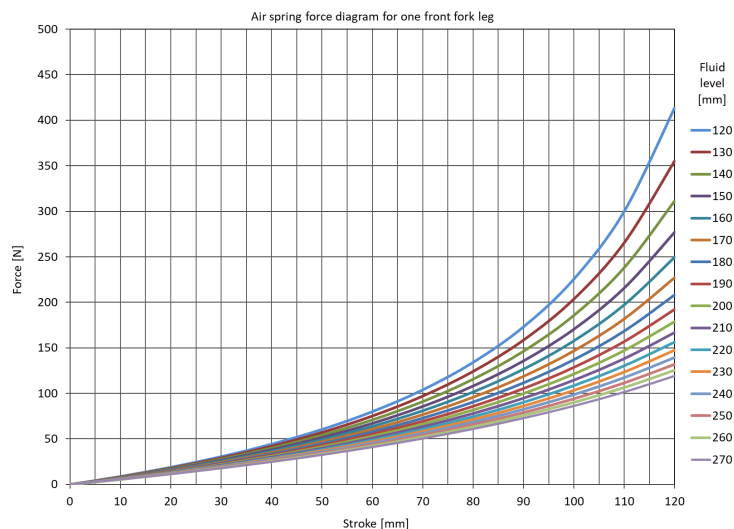

Öhlins products are subject to continuous improvement and development, therefore, although these instructions include the most up-to-date information available at the time of printing, minor updates may occur.

To find the latest information contact an Öhlins distributor. Please contact Öhlins if you have any questions regarding the contents in this document.

Part no. MI_FGK 247_0
Issued 2025-09-26

© Öhlins Group AB. All rights reserved. Any reprinting or unauthorized use without the written permission of Öhlins Group AB is prohibited.

Öhlins Group AB
Box 722
S-194 27 Upplands Väsby, Sweden
Phone +46 8 590 025 00
fax +46 8 590 025 80

