



Kit Contents			
	Description	Part No	Pcs
1	Shock absorber front	AUS 5S00	2
2	Dust boot	10216-02	2
3	Plastic spacer	25602-01	2
4	Spring	49180-39	2
5	Elastic spacer	25601-01	2
6	Upper spring seat	25618-25	2
7	Top pin spacer	24629-41	2
8	Washer	24619-03	2
9	Nut M12	24627-02	2
10	C-spanner	24639-01	1
11	C-spanner	24639-04	1
12	Öhlins sticker kit	10207-01	1
13	Öhlins emblem kit	10207-02	1
14	Öhlins Owners manual		

👁 Note!

Please note that there can be small differences between your product and the images in these instructions.

👁 Note!

Please note that during storage and transport, especially at high ambient temperature, some of the oil and grease used for assembly may leak and stain the packaging. This will not cause damage to the product, wipe off the excessive oil or grease with a cloth.

👁 Note!

Before you install this product, check the kit contents. If anything is missing, please contact an Öhlins dealer.

⚠ Warning!

Before you install this product, read the Öhlins Owner's manual. This product is an important part of the vehicle and the vehicle stability.

Shock Absorber Kit for Audi B8: A4/A5, S4/S5 & RS4/RS5

AUS MS00S1 front

Mounting Instructions



ÖHLINS

MOUNTING INSTRUCTIONS

⚠ Warning!

We strongly recommend to let an Öhlins dealer install this product.

⚠ Warning!

If you work with a lifted vehicle, make sure that it is safely supported to prevent it from tipping over.

👁 Note!

When you work with this product, see the vehicle service manual for vehicle specific procedures and important data.

👁 Note!

Before you install this product clean the vehicle.

1

Raise the vehicle and put it on jack stands.

2

Remove the front wheels.

3

Loosen the bolts for the lower strut attachments.

👁 Note!

Support the wheel hubs in an appropriate way on each side of the vehicle so that the brake hoses can not be damaged.

4

Loosen the upper attachments and remove the original struts from the car. If your OE top mount has a rubber positioned inside the OE top mount, remove it.

5

Install the dust boot (2), the plastic spacer (3), the spring (4), the rubber spacer (5), the upper spring seat (6), the 25mm spacer (7), the OE top mount assembly, the washer (8) and the M12 lock nut (9) according to fig 1. Tighten the lock nut to 35 Nm.

👁 Note!

When tightening the top mount nut, the shock absorber shaft must be held in position with an Allen key.

6

Position the lower spring seat and the lock ring according to fig 2 and tighten with the c-spanner.

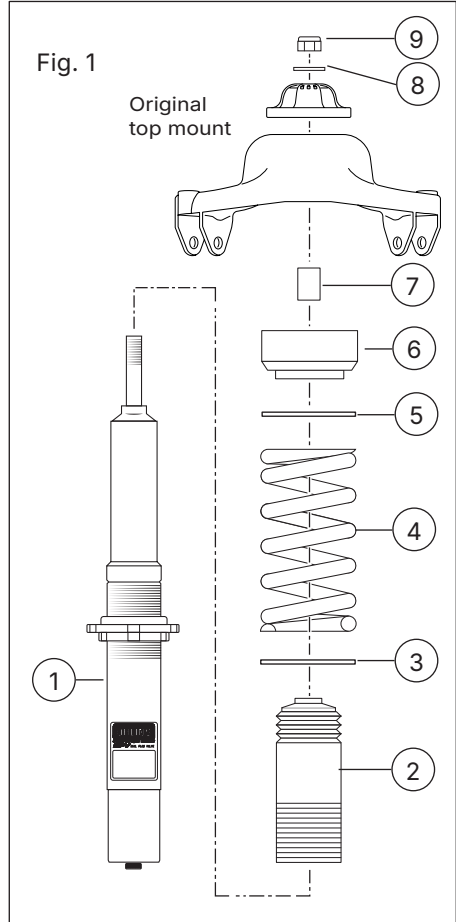

MOUNTING INSTRUCTIONS

7

Fasten the upper attachments.

8

Raise the wheel hub with a jack to remove the freeplay of the lower strut attachment bolts before tightening them.

👁 Note!

Make sure that all bolts are tightened to the correct torque and that nothing fouls or restricts movement of the strut when it is being fully compressed or extended. Test this over the whole steering range from lock to lock. Some of the original bolts need to be replaced when removed. See the service manual for your vehicle or contact an Öhlins dealer.

9

Make sure that all removed parts are reinstalled in the same way as they were before the installation of the Öhlins shock absorber.

ADJUSTMENTS

⚠ Warning!

Before you ride/drive, always make sure that the setup is according to the recommended setup data. Read about adjustments and setting up in the Öhlins Owner's Manual before you make any adjustments. Contact an Öhlins dealer if you have any questions about setting up.

The recommended preload is 10 mm from a free length of 180 mm, giving 170 mm installed length, see fig. 2.

SETUP DATA

Rebound setting		
Track	2-7	clicks
Winding road	5-10	clicks
Street	10-20	clicks
Spring preload	2-15	mm

Recommended spring

49180-39 (120 N/mm)

The actual vehicle height

With the preload in their recommended position, the vehicle is lowered approximately 15mm when compared to the original suspension.

Depending on car model and equipment, the spring preload may vary. Adjust the spring preload until you have reached your desired ride height. Make sure that the spring is always preloaded.

Fig. 2

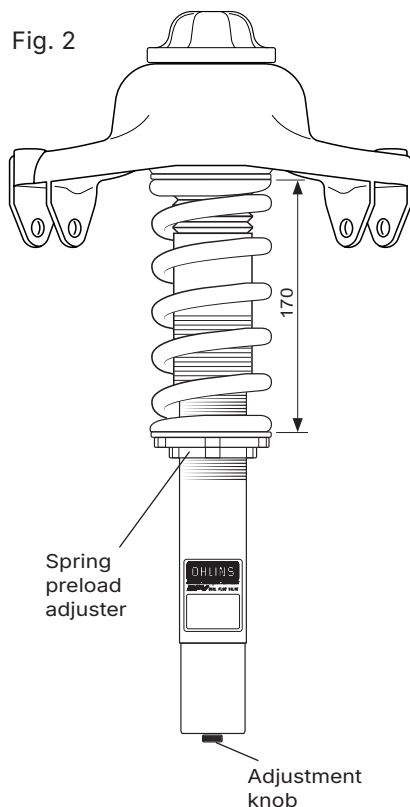

Öhlins products are subject to continuous improvement and development, therefore, although these instructions include the most up-to-date information available at the time of printing, minor updates may occur.

To find the latest information contact an Öhlins distributor. Please contact Öhlins if you have any questions regarding the contents in this document.

Part no. ML_AUS MS00S1_0
Issued 2025-12-11

© Öhlins Group AB. All rights reserved. Any reprinting or unauthorized use without the written permission of Öhlins Group AB is prohibited.

Öhlins Group AB
Box 722
S-194 27 Upplands Väsby, Sweden
Phone +46 8 590 025 00
fax +46 8 590 025 80





Pos nr	Kit Contents		
	Description	Part No	Pcs
1	Shock absorber rear	AUS 6S00	2
2	End eye spacer	24629-42	4
3	Dust boot support	24645-01	2
4	Dust boot	10216-03	2
5	Tie-rap	00231-02	4
6	Lock nut M10	24618-02	2
7	Spring seat adjuster	24651-04	2
8	Lock nut M52	24636-03	2
9	Spring platform M52	24635-03	2
10	Plastic spacer	25602-01	2
11	Spring	49200-11	2
12	Elastic spacer	25601-01	2
13	Upper spring seat	25618-26	2

👁 Note!

Please note that there can be small differences between your product and the images in these instructions.

👁 Note!

Please note that during storage and transport, especially at high ambient temperature, some of the oil and grease used for assembly may leak and stain the packaging. This will not cause damage to the product, wipe off the excessive oil or grease with a cloth.

👁 Note!

Before you install this product, check the kit contents. If anything is missing, please contact an Öhlins dealer.

⚠ Warning!

Before you install this product, read the Öhlins Owner's manual. This product is an important part of the vehicle and the vehicle stability.

Shock Absorber Kit for Audi B8: A4/A5, S4/S5 & RS4/RS5

AUS MS00S1 rear

Mounting Instructions



ÖHLINS

MOUNTING INSTRUCTIONS

⚠ Warning!

We strongly recommend to let an Öhlins dealer install this product.

⚠ Warning!

If you work with a lifted vehicle, make sure that it is safely supported to prevent it from tipping over.

👁 Note!

When you work with this product, see the vehicle service manual for vehicle specific procedures and important data.

👁 Note!

Before you install this product clean the vehicle.

1

Raise the vehicle and put it on jack stands.

2

Remove the rear wheels.

3

Remove the lower and the upper attachments and remove the original shock absorbers.

4

Remove the spring.

5

Adjust the spring seat on the spring preload adjuster according to fig 3. Tighten the lock ring with the c-spanners.

6

Install the Öhlins spring and the spring preload adjuster on the vehicle according to fig 2.

Fig. 1

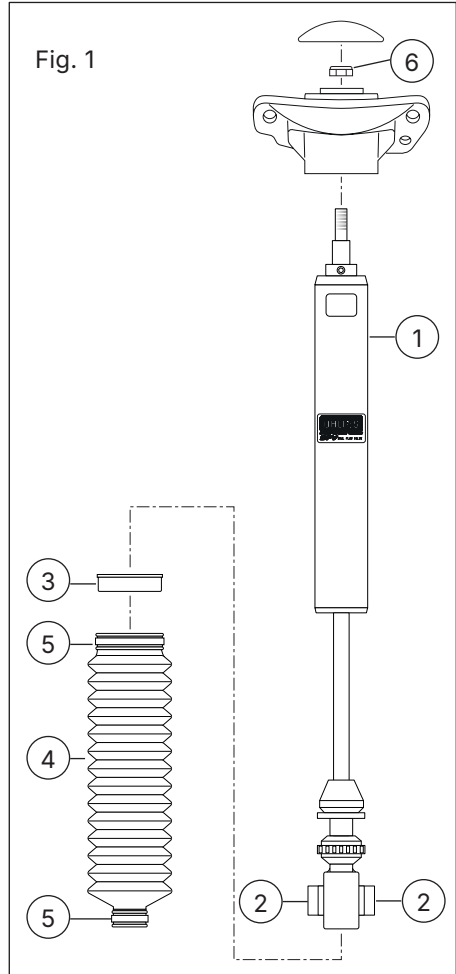

MOUNTING INSTRUCTIONS

7

Mount the parts on the Öhlins shock absorber according to figure 1. Tighten the lock nut to 30 Nm.

8

Install the Öhlins shock absorbers on the vehicle.

👁 **Note!**

Make sure that all bolts are tightened to the correct torque and that nothing fouls or restricts movement of the shock absorber when it is being fully compressed or extended.

9

Make sure that all removed parts are reinstalled in the same way as they were before the installation of the Öhlins shock absorber.

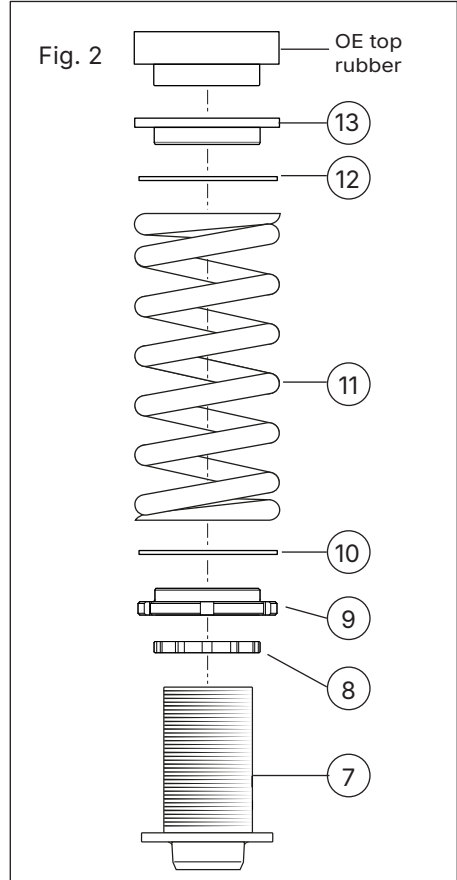

ADJUSTMENTS

⚠ Warning!

Before you ride/drive, always make sure that the setup is according to the recommended setup data. Read about adjustments and setting up in the Öhlins Owner's Manual before you make any adjustments. Contact an Öhlins dealer if you have any questions about setting up.

SETUP DATA

Rebound setting		
Track	2-7	clicks
Winding	5-10	clicks
road		
Street	10-20	clicks
Spring preload adjuster height (X)	30-40	mm

Recommended spring

49200-11 (50 N/mm)

The actual vehicle height

With the preload in their recommended position, the vehicle is lowered approximately 15 mm when compared to the original suspension. Depending on car model and equipment, the spring preload may vary.

Adjust the spring preload until you have reached your desired height. Make sure that the spring is always preloaded.

Fig. 3

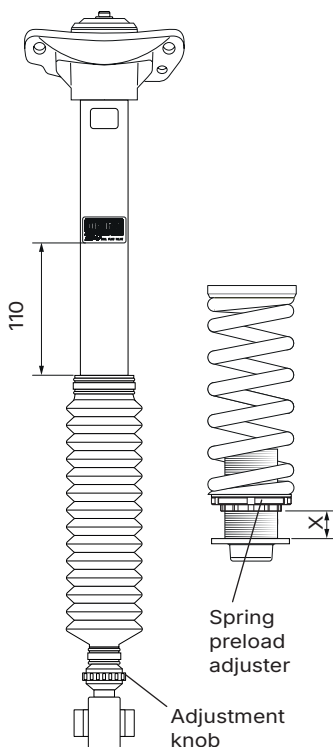

Öhlins products are subject to continuous improvement and development, therefore, although these instructions include the most up-to-date information available at the time of printing, minor updates may occur.

To find the latest information contact an Öhlins distributor. Please contact Öhlins if you have any questions regarding the contents in this document.

Part no. ML/AUS MS00S1_0
Issued 2025-12-11

© Öhlins Group AB. All rights reserved. Any reprinting or unauthorized use without the written permission of Öhlins Group AB is prohibited.

Öhlins Group AB
Box 722
S-194 27 Upplands Väsby, Sweden
Phone +46 8 590 025 00
fax +46 8 590 025 80

