

👁 Note!

Please note that the images in this folder are a general representation of the product and may differ slightly from your product.

👁 Note!

Please note that during storage and transportation, especially at high ambient temperature, some of the oil and grease used for assembling may leak and stain the packaging. This is in no way detrimental to the product, wipe off the excessive oil/grease with a cloth.

Kit Contents

Description	Part No	Pcs
Shock absorber	DMX 0103	1
Spring clip	00516-01	1
Sticker Öhlins	10207-01	1
Owner's manual	07251-04	1
Sticker service schedule	15211-01	1
MX fork & shock		

👁 Note!

No spring included in this kit. See the Spring guide in this folder or contact an Öhlins dealer for advice.

👁 Note!

Before installing this product, check the contents of the kit. If anything is missing, please contact an Öhlins dealer.

⚠ Warning!

Before installing this product, read the Öhlins Owner's Manual. The shock absorber/front fork/steering damper is an important part of your vehicle and will affect the stability.

Shock Absorber for Kawasaki KX85

DMX 0103

Mounting Instructions

MOUNTING INSTRUCTIONS

Install the spring

Note!

Install the spring on the shock absorber before installing the shock absorber on the vehicle.

1

Measure spring free length (A).

2

Loosen the preload lock nut so that you can move the spring platform as far up as needed to install the spring.

3

Put the shock absorber up-side-down in a vice. Install the spring and the spring clip.

Note!

The spring platform and the spring are press fitted. Push hard to install the spring.

4

Measure the spring length. Adjust the spring preload to the recommended setup data in this folder.

Caution!

Tighten the preload lock nut before riding.

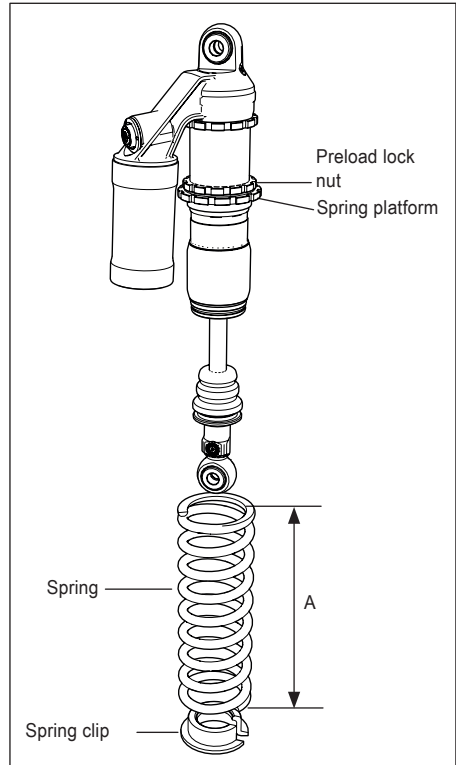

MOUNTING INSTRUCTIONS

Install the Shock Absorber

Warning!

We strongly recommend to let an Öhlins dealer install this product.

Warning!

If you work with a lifted vehicle, make sure that it is safely supported to prevent it from tipping over.

Note!

When you work with this product, see the vehicle service manual for vehicle specific procedures and important data.

Note!

Before you install this product clean the vehicle.

1

Put the motorcycle on a work stand so that the rear wheel barely touches the ground.

2

Refer to the vehicle manual to install the Öhlins shock absorber.

Note!

Lower the vehicle so that the suspension is slightly compressed before you tighten the screws.

Caution!

Make sure that you tighten all screws to the correct torque and that nothing fouls or restricts movement of the shock absorber/front fork/steering damper when the suspension is fully compressed or extended.

ADJUSTMENTS

⚠ Warning!

Before riding, always make sure that the basic settings made by Öhlins are according to recommended Set-up Data. Read about adjustments and setting up in the Öhlins Owner's Manual before you make any adjustments. Contact an Öhlins dealer if you have any questions about setting up.

SETUP DATA

Length	378	mm
Stroke	109	mm
Spring preload approx.	10	mm
Rebound	30	clicks
Compression		
low speed	14	clicks
high speed	II	

Free Sag and Ride Height

R1-R2	25±5	mm
R1-R3	70±5	mm

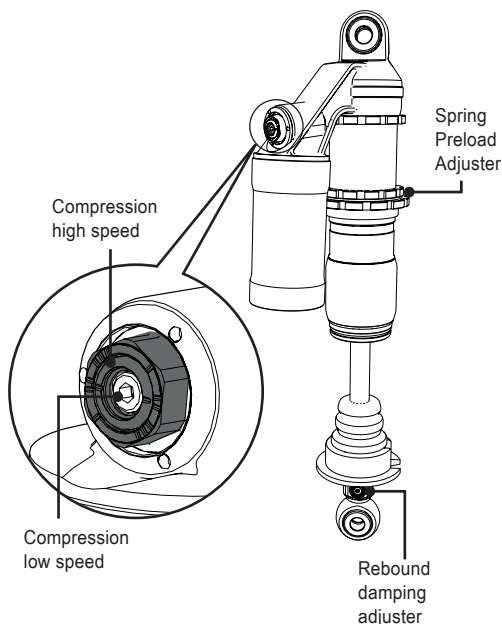

SPRING GUIDE

Rider's weight* (kg/lbs)	Spring	Spring rate
< 35/77	00698-05	42
40/88	00698-06	44
45/99	00698-07	46
50/110	00698-08	48
55/121	00698-09	50
> 60/132	00698-10	52

*Rider's weight: Rider wearing proper riding gear.
Make sure you know your total weight with riding gear.
Riding gear weighs between 5 and 15 kg.

Öhlins products are subject to continuous improvement and development, therefore, although these instructions include the most up-to-date information available at the time of printing, minor updates may occur.

To find the latest information contact an Öhlins distributor. Please contact Öhlins if you have any questions regarding the contents in this document.

Part no. MI_DMX0103_0
Issued 2021-10-08

© Öhlins Racing AB. All rights reserved. Any reprinting or unauthorized use without the written permission of Öhlins Racing AB is prohibited.

Öhlins Racing AB
Box 722
S-194 27 Upplands Väsby, Sweden
Phone +46 8 590 025 00
fax +46 8 590 025 80



www.ohlins.com