



### Kit Contents

	Description	Part No	Pcs
1	Sleeve	24638-01	2
2	Shock absorber	POU 5U40 U01	2
3	Dust boot	10216-01	2
4	Spacer	25602-01	2
5	Helper spring & adapter	U00159-49	2
6	Main Spring	U00159-51	2
7	Spring seat	24637-02	2
8	Front strut mount	U00206-01	2
9	Lock nut M14	24627-04	2
10	C-spanner	24639-03	1
11	C-spanner	24639-01	1
12	Öhlins sticker kit	10207-01	1
13	Öhlins emblem kit	10207-02	1
14	Öhlins Owners Manual		1

#### **⚠ Warning!**

**For off-road use only.** Dedicated kits have been designed specifically for track use and should never be used on the streets.

#### **👁 Note!**

Please note that during storage and transport, especially at high ambient temperature, some of the oil and grease used for assembly may leak and stain the packaging. This will not cause damage to the product, wipe off the excessive oil or grease with a cloth.

#### **👁 Note!**

Please note that there can be small differences between your product and the images in these instructions.

#### **👁 Note!**

Before you install this product, check the kit contents. If anything is missing, please contact an Öhlins dealer.

#### **⚠ Warning!**

Before you install this product, read the Öhlins Owner's manual. This product is an important part of the vehicle and the vehicle stability.

**Shock absorber Kit for 981 BOXSTER • 981 BOXSTER S •  
981 BOXSTER GTS • 981 CAYMAN • 981 CAYMAN S •  
981 CAYMAN GTS 718 BOXSTER • 718 BOXSTER S • 718 CAYMAN •  
718 CAYMAN S • 718 CAYMAN GTS • 718 BOXSTER GTS**

# **POU MU40S1 front**

## **Mounting Instructions**



# MOUNTING INSTRUCTIONS

## **⚠ Warning!**

*We strongly recommend to let an Öhlins dealer install this product.*

## **⚠ Warning!**

*If you work with a lifted vehicle, make sure that it is safely supported to prevent it from tipping over.*

## **👁 Note!**

*When you work with this product, see the vehicle service manual for vehicle specific procedures and important data.*

## **👁 Note!**

*Before you install this product clean the vehicle.*

**1**

Raise the vehicle and put it on jack stands.

**2**

Remove the front wheels.

**3**

Loosen the bolts for the lower strut attachments.

## **👉 Caution!**

*Support the wheel hubs in an appropriate way on each side of the vehicle so that the brake hoses can not be damaged.*

**4**

Loosen the upper attachments. Remove the original struts from the car.

**5**

Cut the dust boot 62 mm from the lower end with a pair of scissors according to fig 2.

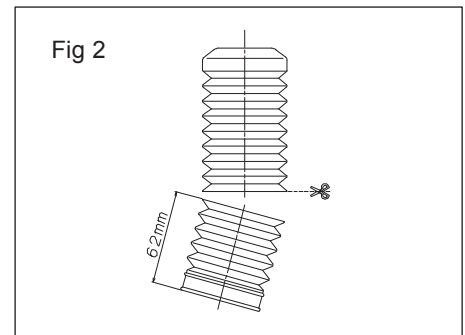
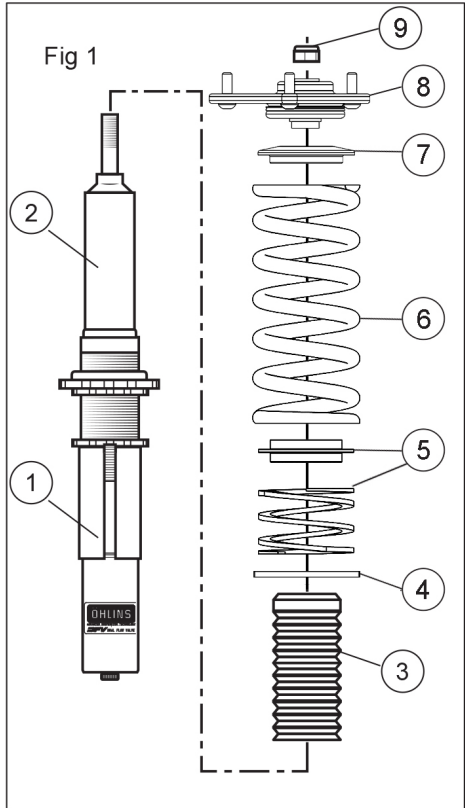

# MOUNTING INSTRUCTIONS

## 6

Fit the sleeve (1), the dust boot (3), the spacer (4), the helper spring with spring adapter (5), the main spring (6), the upper spring seat (7) the Strut mount (8) and the M14 lock nut (9) to the strut according to fig 1. Tighten the lock nut to 35 - 40 Nm. Adjust the spring seat and the lock ring according to fig 4 and tighten to 50 - 60 Nm.

### **Note!**

*When tightening the top mount nut, the shock absorber shaft must be held in position with an Allen key.*

## 7

Fasten the upper attachments to the vehicle.

## 8

Raise the wheel hub with a jack to remove the freeplay of the lower strut attachment bolts before tightening them.

### **Note!**

*Make sure that all bolts are tightened to the correct torque and that nothing fouls or restricts movement of the strut when it is being fully compressed or extended. Test this over the whole steering range from lock to lock.*

## 9

Adjust the height adjuster lock ring according to fig 4 and tighten to 40 - 50 Nm.

## 10

Make sure that all removed parts are reinstalled in the same way as they were before the installation of the Öhlins shock absorber.

### **Note!**

*If the vehicle is equipped with OEM PASM shock absorbers, use Öhlins cancellation kit.*

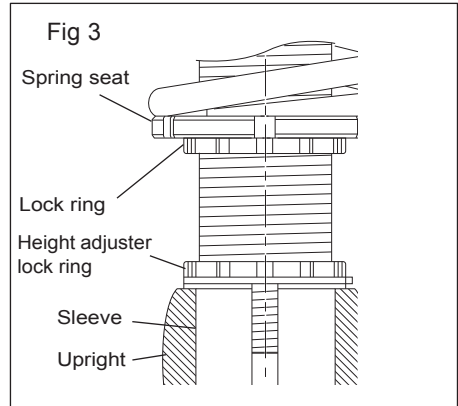

# ADJUSTMENTS

## **⚠ Warning!**

Before you ride/drive, always make sure that the setup is according to the recommended setup data. Read about adjustments and setting up in the Öhlins Owner's Manual before you make any adjustments. Contact an Öhlins dealer if you have any questions about setting up.

## SETUP DATA

### Recommended set-up

Rebound setting

Track	9	clicks
Spring assembly preload length	186	mm
Height adjuster location	57	mm
<b>Spring</b>		
Main Spec H152, ID65	110	N/mm
Helper Spec H135, ID65	0.8	N/mm

### The actual vehicle height

With both the preload and height adjustments in their standard positions, the vehicle is lowered approximately 20 mm when compared to the original suspension. As the height adjuster is turned one rotation, the position moves 1.5 mm.

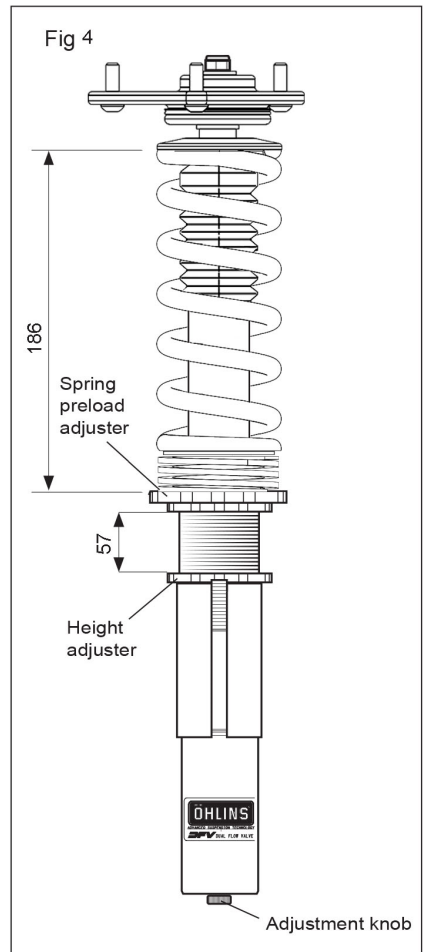

Öhlins products are subject to continuous improvement and development, therefore, although these instructions include the most up-to-date information available at the time of printing, minor updates may occur.

To find the latest information contact an Öhlins distributor. Please contact Öhlins if you have any questions regarding the contents in this document.

Part no. U00250-03\_2  
Issued 2023-06-07

© Öhlins Racing AB. All rights reserved. Any reprinting or unauthorized use without the written permission of Öhlins Racing AB is prohibited.

Öhlins USA  
703 South Grove St  
Hendersonville NC, 28792

Phone 1-800-336-9029  
fax 828-692-0595



[www.ohlinsusa.com](http://www.ohlinsusa.com)



#### Kit Contents

	Description	Part No	Pcs
1	Sleeve	24638-05	2
2	Shock absorber	POU 6U40 U01	2
3	Dust boot	10216-01	2
4	Plastic spring spacer	25602-01	2
5	Helper spring & adapter	U00159-49	2
6	Main Spring	U00159-58	2
7	Rubber spring spacer	25601-01	2
8	Strut mount	U00212-01	2
9	Lock nut M14	24627-04	2

#### ⚠ Warning!

**For off-road use only.** Dedicated kits have been designed specifically for track use and should never be used on the streets.

#### 👁 Note!

Please note that during storage and transport, especially at high ambient temperature, some of the oil and grease used for assembly may leak and stain the packaging. This will not cause damage to the product, wipe off the excessive oil or grease with a cloth.

#### 👁 Note!

Please note that there can be small differences between your product and the images in these instructions.

#### 👁 Note!

Before you install this product, check the kit contents. If anything is missing, please contact an Öhlins dealer.

#### ⚠ Warning!

Before you install this product, read the Öhlins Owner's manual. This product is an important part of the vehicle and the vehicle stability.

**Shock absorber Kit for 981 BOXSTER • 981 BOXSTER S •  
981 BOXSTER GTS • 981 CAYMAN • 981 CAYMAN S •  
981 CAYMAN GTS 718 BOXSTER • 718 BOXSTER S • 718 CAYMAN •  
718 CAYMAN S • 718 CAYMAN GTS • 718 BOXSTER GTS**

# **POU MU40S1 rear**

## Mounting Instructions



# MOUNTING INSTRUCTIONS

## **⚠ Warning!**

*We strongly recommend to let an Öhlins dealer install this product.*

## **⚠ Warning!**

*If you work with a lifted vehicle, make sure that it is safely supported to prevent it from tipping over.*

## **👁 Note!**

*When you work with this product, see the vehicle service manual for vehicle specific procedures and important data.*

## **👁 Note!**

*Before you install this product clean the vehicle.*

**1**

Raise the vehicle and put it on jack stands.

## **⚠ Warning!**

*Ensure that it is securely supported.*

**2**

Remove the rear wheels.

**3**

Remove the interior in the rear compartment to access the top mount nuts.

**4**

Remove the lower and the upper attachments and remove the original shock absorbers.

**5**

Cut the dust boot 62 mm from the lower end with a pair of scissors according to fig 2.

**6**

Adjust the spring seat and the lock ring according to fig 4 and tighten to 50 - 60 Nm. Fit the sleeve (1), the dust boot (3), the plastic spacer (4), the helper spring with spring adapter (5), the main spring (6), the rubber spacer (7), the strut mount (8) and the M14 lock nut (9) to the strut according to fig 1.

## **👉 Caution!**

*When tightening the top mount nut, the shock absorber shaft must be held in position with an Allen key.*

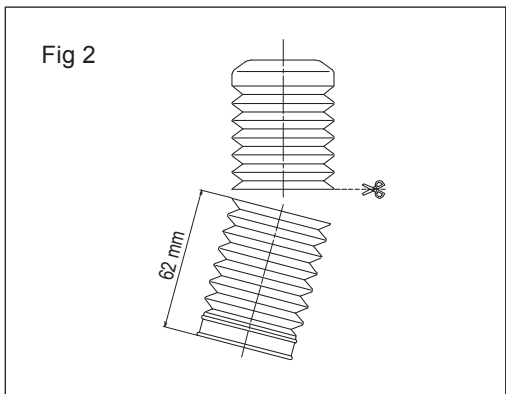
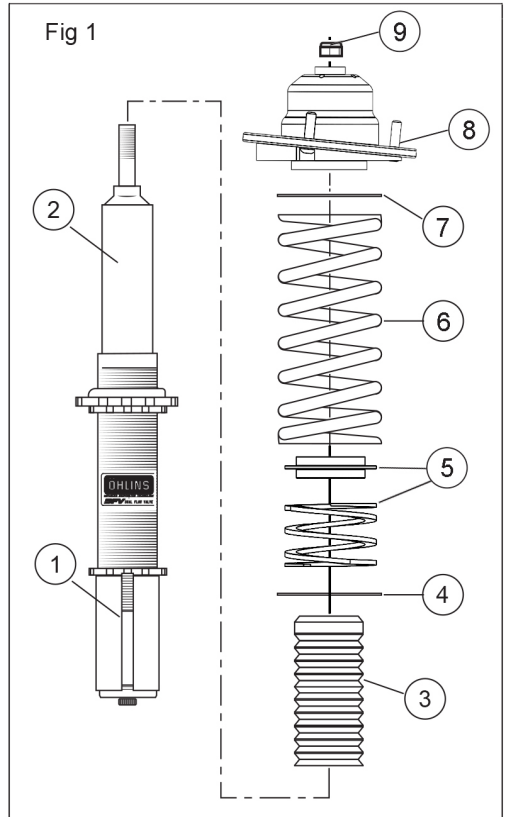

# MOUNTING INSTRUCTIONS

7

Install the Öhlins shock absorbers on the vehicle and fasten the upper attachments.

8

Raise the wheel hub with a jack to remove the freeplay of the lower strut attachment bolts before tightening them.

9

Make sure that all removed parts are reinstalled in the same way as they were before the installation of the Öhlins shock absorber.

**Note!**

*Make sure that all bolts are tightened to the correct torque and that nothing fouls or restricts movement of the shock absorber when it is being fully compressed or extended.*

10

Tighten the height adjuster lock ring to 40 - 50 Nm according to fig 3.

**Note!**

*If the vehicle is equipped with OEM PASM shock absorbers, use Öhlins cancellation kit.*

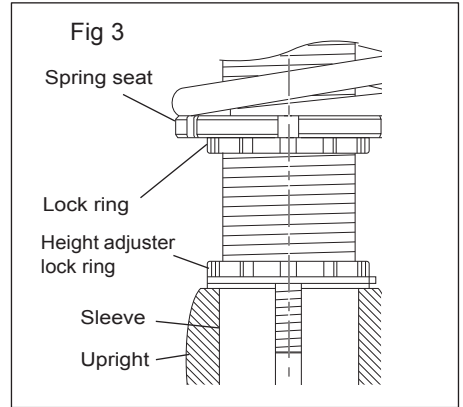

## **⚠ Warning!**

Before you ride/drive, always make sure that the setup is according to the recommended setup data. Read about adjustments and setting up in the Öhlins Owner's Manual before you make any adjustments. Contact an Öhlins dealer if you have any questions about setting up.

# SETUP DATA

## Recommended set-up

### Rebound setting

Track 4 clicks

Spring assembly preload length 189 mm

Height adjuster location 101 mm

### Spring

Main Spec H152, ID65 130 N/mm

Helper Spec H135, ID65 0.8 N/mm

### The actual vehicle height

With both the preload and height adjustments in their standard positions, the vehicle is lowered approximately 20 mm when compared to the original suspension. As the height adjuster is turned one rotation, the position moves 1.5 mm.

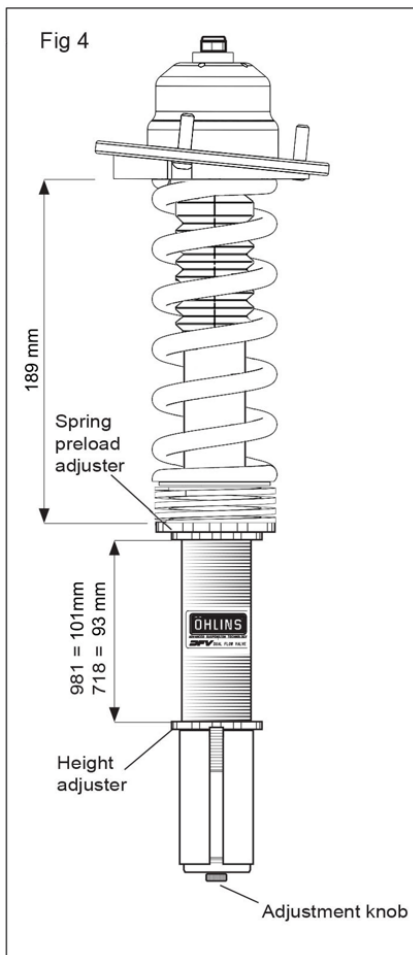

Öhlins products are subject to continuous improvement and development, therefore, although these instructions include the most up-to-date information available at the time of printing, minor updates may occur.

To find the latest information contact an Öhlins distributor. Please contact Öhlins if you have any questions regarding the contents in this document.

Part no. U00250-03\_2  
Issued 2023-06-07

© Öhlins Racing AB. All rights reserved. Any reprinting or unauthorized use without the written permission of Öhlins Racing AB is prohibited.

Öhlins USA  
703 South Grove St  
Hendersonville NC, 28792

Phone 1-800-336-9029  
fax 828-692-0595

