

**Note!**

Please note that there can be small differences between your product and the images in these instructions.

**Note!**

Please note that during storage and transport, especially at high ambient temperature, some of the oil and grease used for assembly may leak and stain the packaging. This will not cause damage to the product, wipe off the excessive oil or grease with a cloth.

**Kit Contents**

Description	Part No	Pcs
Cartridge kit	FKR 202	1
O-ring 35x2	00338-64	2
O-ring 40x2.5	00576-02	2
Main spring 9.5 N/mm	04744-95	2
Main spring 10.0 N/mm	04744-10	2
Main spring 10.5 N/mm	04744-05	2
Sticker set Öhlins	-	-
Owner's manual	07291-02	1
Optional preload tube*	01460-76	2

**Caution!**

\*The optional preload tube can be used to extend the stroke to 130 mm. To extend stroke contact an Öhlins service center.

**Note!**

Before you install this product, check the kit contents. If anything is missing, please contact an Öhlins dealer.

**Warning!**

Before you install this product, read the Öhlins Owner's manual. This product is an important part of the vehicle and the vehicle stability.

Cartridge kit for Yamaha YZF-R1, Yamaha YZF-R6

**FKR 202**

Mounting Instructions



# MOUNTING INSTRUCTIONS

## **⚠ Warning!**

*We strongly recommend to let an Öhlins dealer install this product.*

## **⚠ Warning!**

*If you work with a lifted vehicle, make sure that it is safely supported to prevent it from tipping over.*

## **👁 Note!**

*When you work with this product, see the vehicle service manual for vehicle specific procedures and important data.*

## **👁 Note!**

*Before you install this product clean the vehicle.*

## **⚠ Warning!**

*Spring compression creates a potential danger because of the violent force that loaded springs are capable of. Beware of this when you work with the front fork.*

Tool	Part no	Applies	Size
Vehicle service manual			
Torque wrench 10-130 Nm		Torque	
Heat gun		Soften thread locker	
Hex key		Compression and rebound adjuster	3 mm
Extended hex key		Cylinder tube assembly	14 mm
Socket		Main preload adjuster	14 mm
Wrench		Spring support	19 mm
Suspension fluid	01309-xx		
Grease	00146-01		100 g
Loctite 2400	01791-25		50 ml
Loctite 2700	01791-27		50 ml
Shaft extension tool	01765-03		
Seal head tool	01797-07		
Clip	02810-01		
Top cap tool	00797-08		
Clamp tool	24670-01	24669-02	
Sleeve	24669-02	Original inner tube	43 mm

# MOUNTING INSTRUCTIONS

## 1 Remove original front fork

### 👁 **Note!**

*The following procedure applies to both front fork legs.*

**1**

Put the motorcycle on a workstand so that the front wheel barely touches the ground.

### ⚠ **Warning!**

*Make sure the vehicle is securely supported so that it will not fall over.*

**2**

Remove front fender, brake calipers, speed sensor (if present) and front wheel.

**3**

Release main spring preload fully (if present).

**4**

Note front fork leg position.

**5**

Loosen upper triple clamp.

**6**

Loosen (do not remove) top cap ½ turn.

**7**

Loosen lower triple clamp.

**8**

Remove front fork legs from triple clamps.

**[24670-01 Clamp tool]**

**[24669-02 Sleeve 43]**

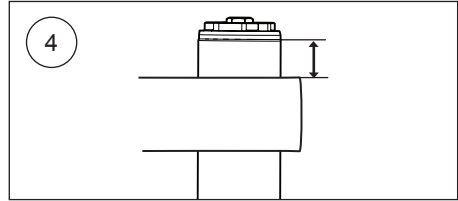

# MOUNTING INSTRUCTIONS

## 2 Disassemble original front fork

### **Note!**

*The following procedure applies to both front fork legs.*

---

**1**

Remove top cap from outer tube.

**2**

Slide outer tube down until it stops.

**3**

Remove top cap from shaft according to instructions in the vehicle service manual.

**4**

Remove main spring and associated parts according to instructions in the vehicle service manual.

**5**

Drain front fork leg from suspension fluid.

**6**

Remove outer tube from inner tube according to instructions in the vehicle service manual.

**7**

Remove inner tube lock screw.

### **Warning!**

*If lock screw is not removed inner tube and fork bottom will be damaged.*

---

### **Warning!**

*Inner tube thread must be repaired before removing the inner tube.*

---

**8**

Install inner tube tool on inner tube. Do not place tool at sealing or gliding surface.

**[00786-05 inner tube tool]**

**9**

Soften thread locker between inner tube and fork bottom with a heat gun.

**[Heat gun]**

**10**

Remove inner tube from fork bottom.

**11**

Remove cartridge from inner tube.

# MOUNTING INSTRUCTIONS

## 3 Install Öhlins cartridge kit

### 👁 **Note!**

The following procedure applies to both front fork legs.

### 👉 **Caution!**

The cartridge kit is divided into compression and rebound cartridges. Install compression cartridge marked "COMP" in left hand side front fork leg. Install rebound cartridge marked "REB" in right hand side front fork leg.

1

Remove top cap, spring support and preload tube.

2

Remove cylinder tube assembly from shaft assembly.

3

Remove adaptor ring from cylinder tube assembly.

4

Clean and degrease inner tube, fork bottom and adaptor ring.

5

Install o-ring on adaptor ring. Apply grease on o-ring.

**[00338-64 o-ring]**

**[00146-01 grease]**

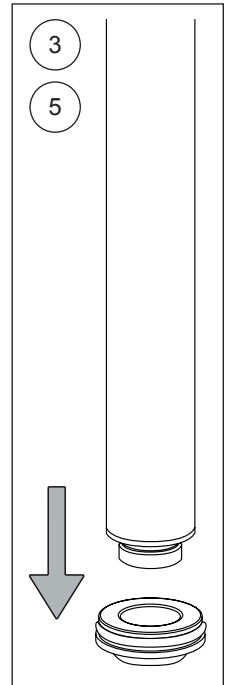
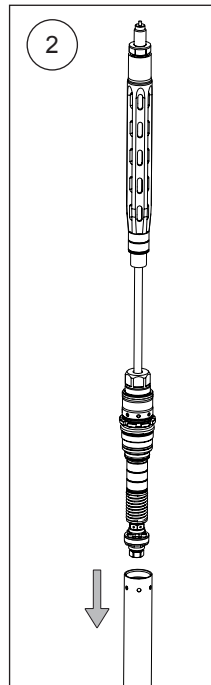
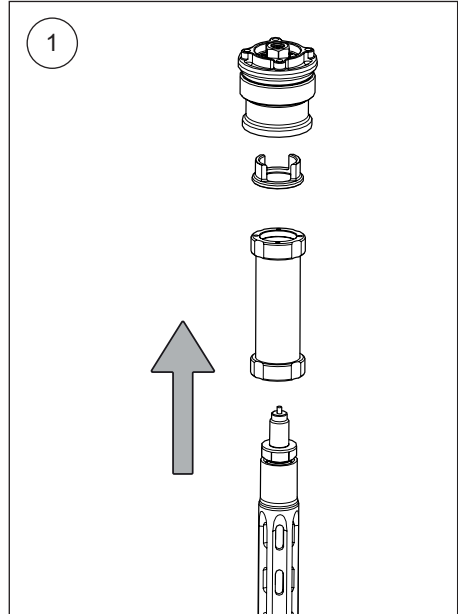

# MOUNTING INSTRUCTIONS

6

Install adaptor ring in inner tube.

7

Install inner tube using inner tube tool.  
Apply Loctite 2700. Tighten to 130 Nm.

[24670-01 Clamp tool]

[24669-02 Sleeve 43]

[01791-27 Loctite 2700]

**Note!**

To get the correct torque, make sure to place the torque wrench in a 90 degree angle to the Fork tube tool.

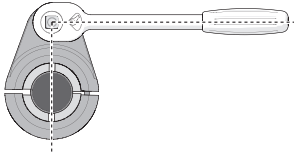

8

Install cylinder tube assembly in front fork leg with an extended hex key. Apply Loctite 2400 on adaptor thread. Tighten to 60 Nm.

[Extended hex key 14 mm]

[01791-25 Loctite 2400]

9

Install outer tube according to instructions in the vehicle service manual.

10

Pour approximately 0.5 litre Öhlins suspension fluid in front fork leg.

**Warning!**

Fluid level must be approximately 50 mm above top of cylinder tube assembly.

11

Install tool on shaft extension.

[01765-03 shaft extension tool]

12

Install tool on seal head.

[01797-07 seal head tool]

**Note!**

Make sure teeth are securely connected to seal head.

13

Compress top out spring fully and insert clip.

[02810-01 clip]

**Warning!**

If top out spring is not completely compressed, adjust shaft extension tool to achieve complete compression of top out spring.

14

Insert shaft assembly in front fork leg.

**Warning!**

Make sure no air is trapped in piston by carefully pumping shaft assembly up and down with piston below fluid surface.

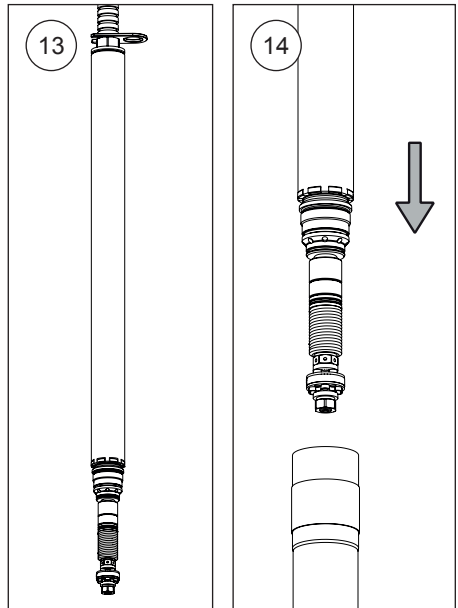
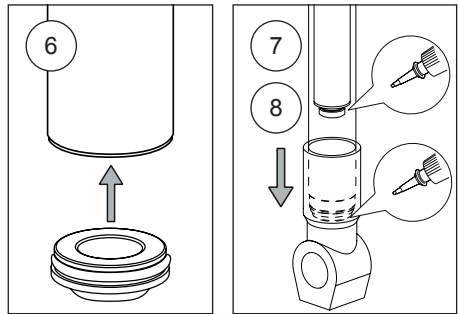

# MOUNTING INSTRUCTIONS

**15**

Install shaft assembly and tighten with your hand.

**16**

Remove clip and shaft extension tool.

**17**

Tighten seal head to 30 Nm and remove seal head tool.

**18**

Make sure that shaft assembly and outer tube are in their bottom positions.

Set suspension fluid level according to chapter "Setup Data".

**19**

Install tool on shaft extension. Install preload tube (A), main spring (B) and spring support (C) over shaft extension tool. Select main spring according to chapter "Main spring guide".

**[01765-03 shaft extension tool]**

**20**

Pull up shaft assembly and grab spring support with a wrench.

**[Wrench 19 mm]**

**21**

Remove shaft extension tool.

**22**

Make sure that compression and rebound adjusters are fully open before installing top cap. Use a hex key to open compression and rebound adjusters.

**[Hex key 3 mm]**

**23**

Install o-ring on top cap. Apply grease on o-ring and thread.

**[00576-02 o-ring]**

**[00146-01 grease]**

**24**

Install top cap on shaft extension. Tighten to 20 Nm.

**[Socket 14 mm]**

**25**

Remove wrench from spring support.

**26**

Pull up outer tube. Make sure front fork leg is in a fully extended position. Use top cap tool to tighten top cap to outer tube. Tighten to 10 Nm. **[00797-08 top cap tool]**

**27**

Set compression, rebound and main spring adjusters according to chapter "Setup Data". Use a hex key for compression and rebound adjusters. Use a socket for main spring preload adjuster.

**[Hex key 3 mm]**

**[Socket 14 mm]**

**28**

Install front fork legs in vehicle at recommended front fork leg position, according to chapter "Setup data".

**29**

Remaining installation, instructions according to vehicle service manual.

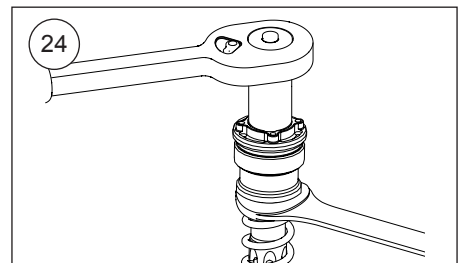
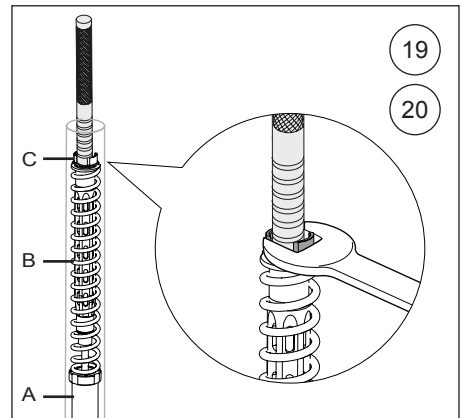

# SETUP DATA

## Recommended setup

Compression adjustment	14	clicks
Rebound adjustment	14	clicks
Suspension fluid level	180	mm
Minimum suspension fluid level	200	mm
Suspension fluid part number	01309-xx	
Front fork leg position	Standard	

# MAIN SPRING GUIDE

Make sure you choose the correct main spring for your rider weight, driving style and preferences. Below you find a general recommendation of main spring rate for your weight. Contact an authorized Öhlins service center for advice.

## 👁 Note!

Only 8790-xx main springs are packed in pairs.

Rider weight [kg]	50	60	70	80	90	100	110
Spring rate [N/mm]	9	9	9,5	10	10,5	10,5	11
Preload [mm]	4	6	5	5	4	6	6
Part number (pair)	08790-90	08790-90	08790-95	08790-10	08790-05	08790-05	08790-11
Part number (single)	04744-90	04744-90	04744-95	04744-10	04744-05	04744-05	04744-11

Air spring force diagram

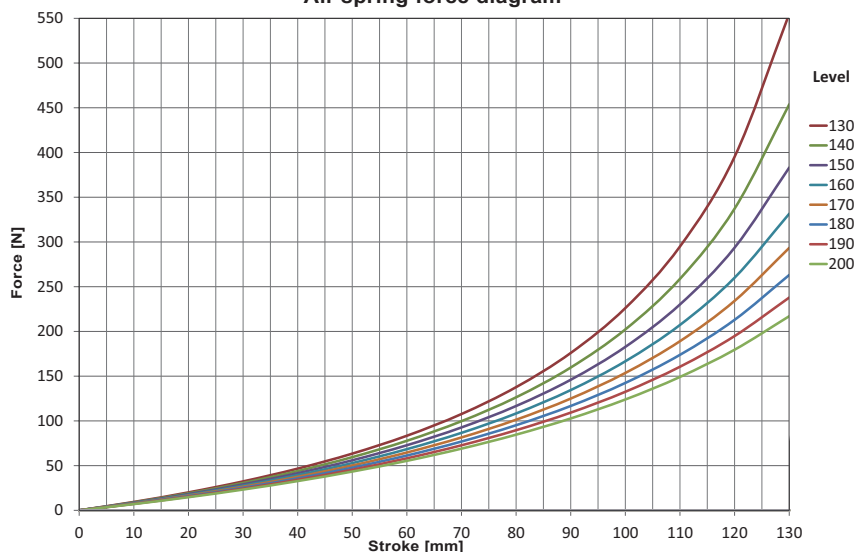

Öhlins products are subject to continuous improvement and development, therefore, although these instructions include the most up-to-date information available at the time of printing, minor updates may occur.

To find the latest information contact an Öhlins distributor. Please contact Öhlins if you have any questions regarding the contents in this document.

Part no. MI\_FKR202\_0  
Issued 2025-10-01

© Öhlins Racing AB. All rights reserved. Any reprinting or unauthorized use without the written permission of Öhlins Racing AB is prohibited.

Öhlins Racing AB  
Box 722  
S-194 27 Upplands Väsby, Sweden  
Phone +46 8 590 025 00  
fax +46 8 590 025 80



[www.ohlins.com](http://www.ohlins.com)