

👁 Note!

Before installing this product, check the contents of the kit. If anything is missing, please check an Öhlins dealer.

Kit Contents

Description	Part No	Pcs
Shock absorber	HO 810	2
Bracket, mudguard	61125-01	1
Screw M6x8	05404-11	1
Screw M8x35	00432-01	2
Screw M6x45	01046-62	2
Screw M6x14	00382-16	1
Sleeve 7/13.9-10	61123-14	2
Washer 6.4/18/1.6	00426-04	1
Tool preload adjuster	03199-03	1
Sticker set "ÖHLINS"	10207-01	1
Owners manual road & track	07241-02	1

Alternative spring

Spring46/200/prog15-24N/mm	60360-03	2
----------------------------	----------	---

👁 Note!

Please note that this image is a general representation of the product and may differ slightly from your product.

👁 Note!

Please note that during storage and transportation, especially at high ambient temperature, some of the oil and grease used for assembling may leak and stain the packaging. This is in no way detrimental to the product, wipe off the excessive oil/grease with a cloth.

⚠ Warning!

Before installing this product, read the Öhlins Owner's Manual. The shock absorber is an important part of your vehicle and will affect the stability.

Shock Absorber for HONDA PCX 150/HYBRID-2018

HO 810

Mounting Instructions

MOUNTING INSTRUCTIONS

⚠ Warning!

It is advisable to have an Öhlins dealer install the shock absorber.

⚠ Warning!

If working on a raised vehicle, ensure it is securely supported so that it will not tip over.

👁 Note!

Before mounting this product clean the vehicle thoroughly.

👁 Note!

When working on this product, always see the Vehicle Service Manual for vehicle specific procedures and important data.

1

Put the motorcycle on a work stand so that the rear wheel barely touches the ground. Make sure the motorcycle is in a stable position.

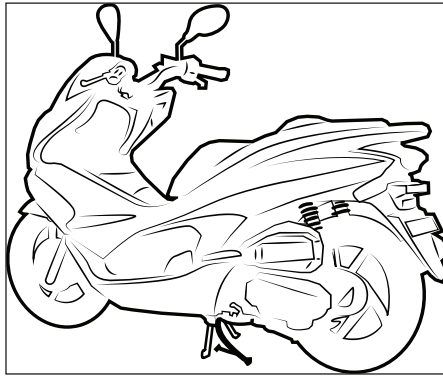

2

Open the seat by the ignition key.

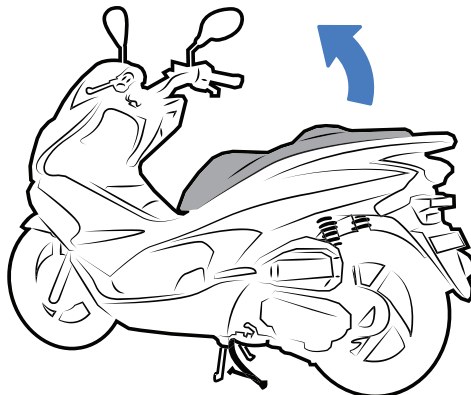

MOUNTING INSTRUCTIONS

3

Remove the plastic cover **(A)** by loosening the screws **(1)** **(2)**.

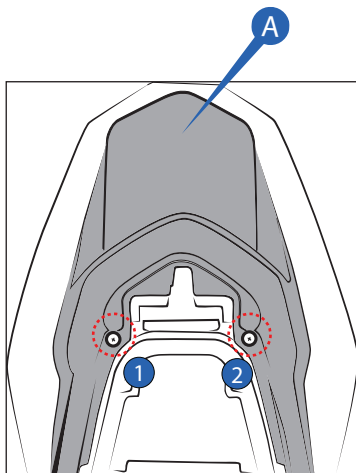

4

Remove the grab bar **(B)** by loosening the screws **(1)** **(2)** **(3)** **(4)** **(5)** **(6)**.

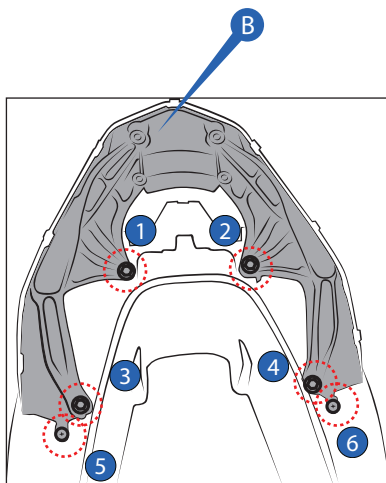

MOUNTING INSTRUCTIONS

5

Remove the storage box © by loosening the screws ①②③④⑤ and unlock plastic clip lock ⑥⑦ then release the rubber band ⑧ to unlock the battery set ④.

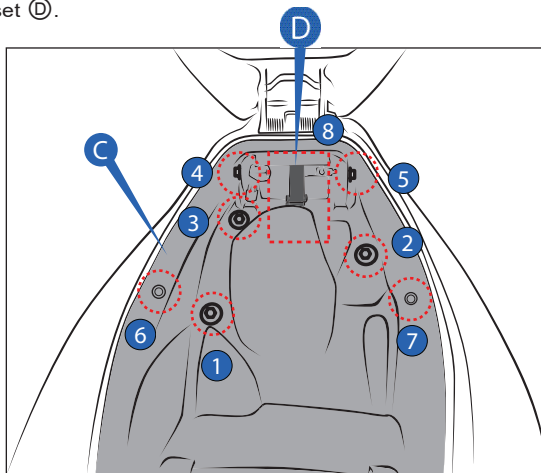

MOUNTING INSTRUCTIONS

6

Remove the left plastic fairing **E** as per following instructions:

- 6.1 Loosen the screws **1** **2**
- 6.2 Loosening the screws **3** **4** **5**
- 6.3 Unclip the plastic clip lock **6** **7**
- 6.4 Unplug the rear light wirings **8** **9**

Repeat the operation 6.2, 6.3 on the opposite side for remove the right plastic fairing **F**

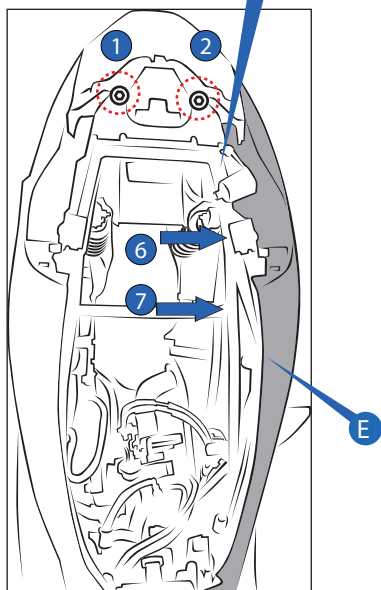
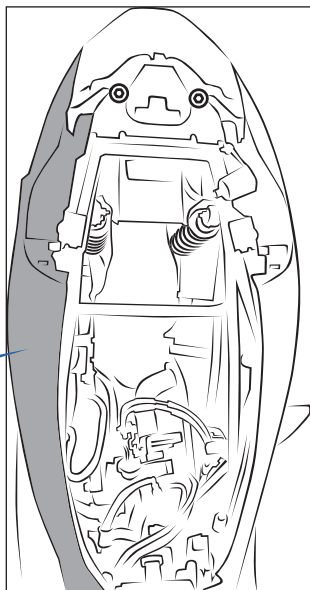
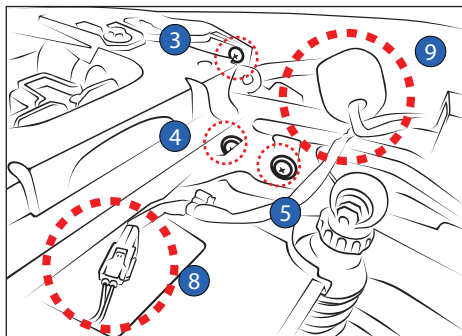

MOUNTING INSTRUCTIONS

7

Unlock the plastic clip locks ① ② placed underneath the rear mudguard in order to remove the tail light ③.

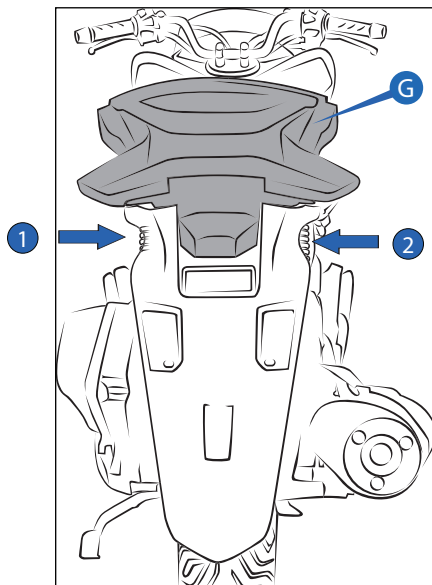

8

Remove the rear mudguard ④ by loosening the screw ①.

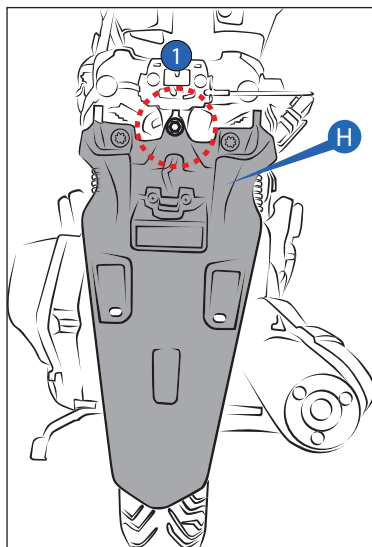

MOUNTING INSTRUCTIONS

HONDA PCX HYBRID

👁 **Note!**

No. 9 and 10 apply to HONDA PCX HYBRID only

9

Remove the ground wire (P) by loosening the screw (1).

10

Dislocate the hybrid battery (Q) by loosening the screws (2)(3)(4)(5) in order to access to the top mounting bolts (6)(7).

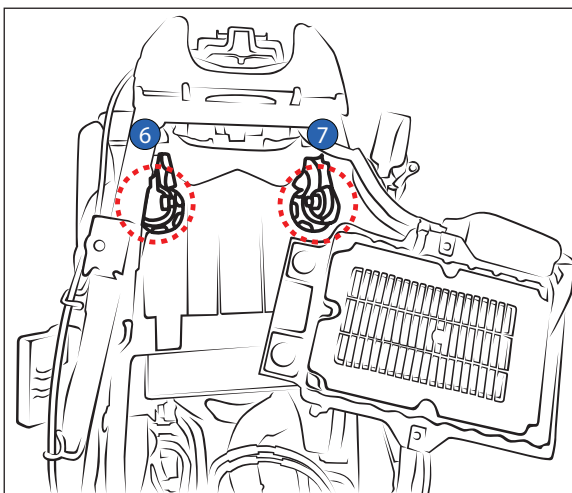
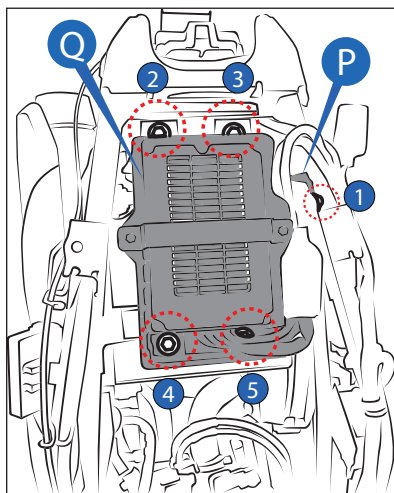

MOUNTING INSTRUCTIONS

11

Remove the exhaust muffler **J** by loosening the screws **1** **2** **3**, in order to access the RH shock absorber lower mounting point.

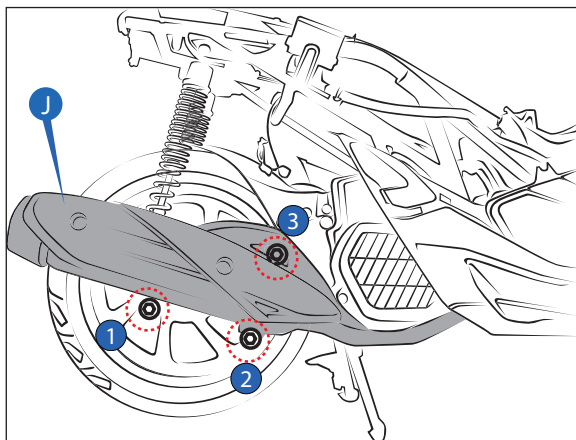

12

Remove the plastic cover **K** by loosening the screws **1** **2** in order to access the air box mounting screws located underneath.

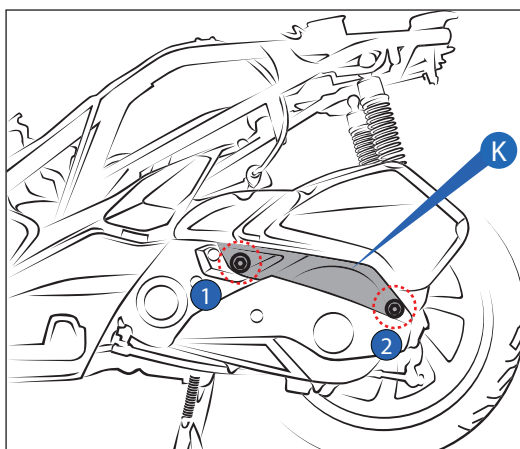

MOUNTING INSTRUCTIONS

13

Release the air box **L** by loosening the screws **1** **2** **3** in order to access to the shock absorber lower mounting point.

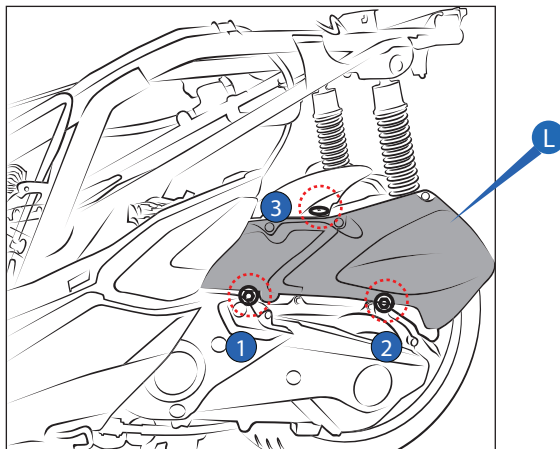

14

Remove the standard shock absorber by loosening the upper and lower mounting bolts **1** **2**

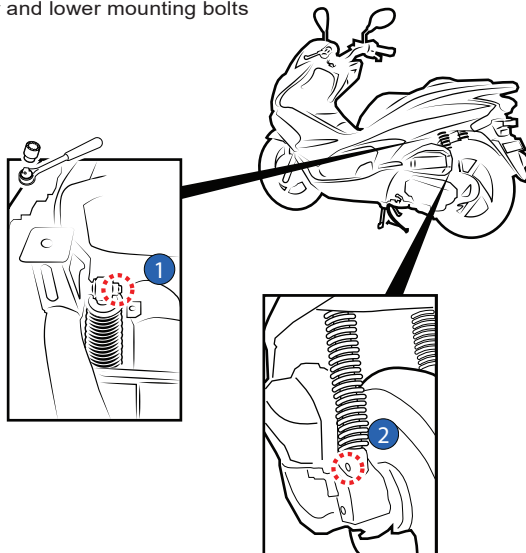

MOUNTING INSTRUCTIONS

15

Install the Öhlins shock absorber by tightening the upper ① and lower ② mounting bolts.

Tighten at a torque value as specified in the vehicle service manual.

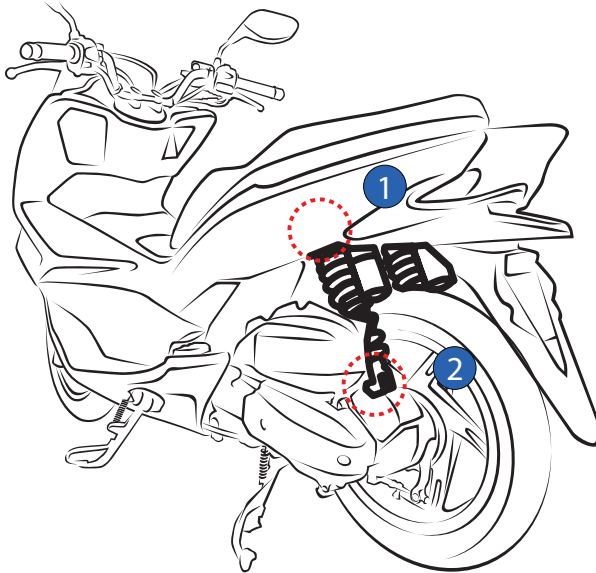

Note!

Lower the vehicle so that the suspension is slightly compressed before tightening the screws.

Caution!

Ensure that all screws are tightened to the correct torque and that nothing fouls or restricts movement of the shock absorber when the suspension is fully compressed or extended.

MOUNTING INSTRUCTIONS

16

In order to ensure proper clearances between the airbox and the Öhlins shock absorber:

16.1 Reinstall the airbox by placing the sleeve 61123-12 between airbox and gearbox. Tighten by using the screw 01046-02 at the torque value recommended in the vehicle service manual (see diagram P1)

16.2 Join the airbox (M) and the rear mudguard (N) by using the bracket 61125-01 and the screws mentioned in the diagram P2

17

Reverse all procedure as necessary.

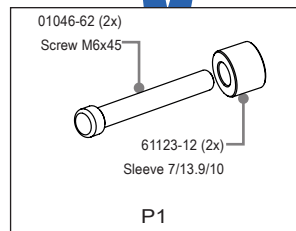
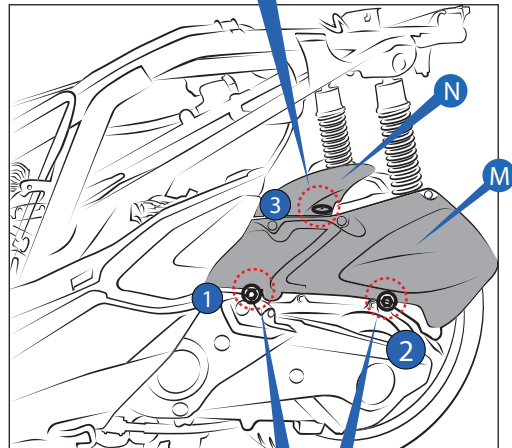
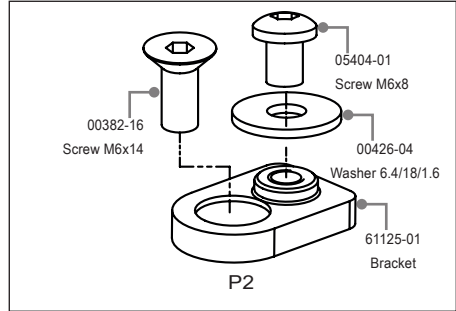

ADJUSTMENTS

⚠ Warning!

Before riding, always make sure that the basic settings made by Öhlins are according to recommended Set-up Data. Read about adjustments and setting up in the Öhlins Owner's Manual before you make any adjustments. Contact an Öhlins dealer if you have any questions about setting up.

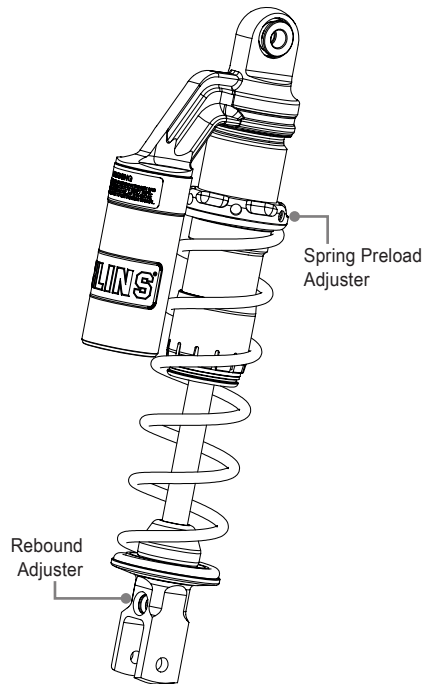

SET-UP DATA

Recommended set-up

Spring Preload..... 3 mm.
Rebound adjuster 15 Clicks

Shock absorber data

Length 348 mm.
Stroke 104 mm.

Spring data

Part No 60360-02
Free spring length 200 mm.
Spring rate Prog.12-19 N/mm.
Preload adj.range [0-14] mm.
For rider's weight Below 80 kg

Installed Spring

Alternative Spring

60360-03
200 mm.
Prog.15-24 N/mm.
[0-14] mm.
Above 80 kg

👁 Öhlins products are subject to continuous improvement and development, therefore, although these instructions include the most up-to-date information available at the time of printing, minor updates may occur.

To find the latest information contact an Öhlins distributor. Please contact Öhlins if you have any questions regarding the contents in this document.

Part no. MI_HO 810_EN_2
Issued 2019-12-18

© Öhlins Asia Co. Ltd. All rights reserved. Any reprinting or unauthorized use without the written permission of Öhlins Racing AB is prohibited.

Öhlins Asia Co. Ltd
700/937 Moo5, Tambol Nongkhaga,
Amphur Phantong, Chonburi Province
20160 Thailand



www.ohlins.com